



MediaMaster® 100s – Mounting Instructions

The diagram below shows a typical mounting procedure into a fiberglass panel. **Always follow proper safety procedures. Wear eye-protection at all times with a dust mask and gloves when cutting.** A mounting template is included to aid in measuring and marking the mounting surface before cutting or drilling.

! IMPORTANT Before drilling or cutting, make sure there is adequate space behind the mounting surface to fit the MM100s, including its wire harness.

1. Press along the perforation to remove the center section of the mounting template. (Discard the center section.) The template can be used to verify there is sufficient flat surface area for mounting and as a guide for cutting the opening. Tape the template to the mounting location and mark the surface for cutting the opening and drilling pilot holes.
2. Use a jigsaw or rotary tool to cut an opening in the mounting surface. If necessary, use a file or sandpaper to adjust the opening for proper fitment and smooth the edges.
3. Place the MM100s into the opening and check that the mounting holes remain aligned with the pilot hole marks taken from the template. If not, adjust and mark new holes as necessary.
4. Remove the MM100s and drill four (4) pilot holes in the mounting surface at the pilot hole marks.
5. Peel the adhesive backing from the mounting gasket and affix to the rear of the bezel. Connect all wiring and place the MM100s into the opening.
6. Secure the MM100s using the four (4) stainless steel screws. Press the trim ring onto the front of the MM100s.

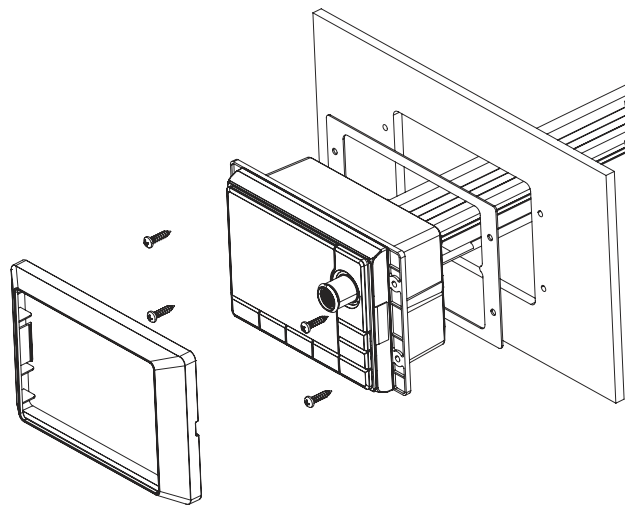



MediaMaster® 100s – Mounting Template

! IMPORTANT This file must be printed actual size (100%). Printer output options such as “Fit to Page” and “Shrink Oversized Pages” will change the size of the template. Always double-check measurements.

