



**OWNER'S OPERATION**

**and**

**MAINTENANCE MANUAL**

*A Division of*





Thank you for your selection of Pleasurecraft (PCM) Marine Power for your boating needs. We welcome you to Team PCM, which puts you in the company of tens of thousands of boaters who have relied on Pleasurecraft inboards as their power of choice for over 20 years.

When you chose PCM, you selected the utmost in premium power for your boating application. Pleasurecraft is the world's largest manufacturer of gasoline marine inboards, and the clear-cut leader in cutting edge technology. Over the years, we have introduced many breakthrough innovations that quickly became industry standards. The pyramidal exhaust system, light-weight transmission, computerized engine control and the Fuel Control Cell (FCC) are all PCM innovations. No matter which PCM model you purchased, you can be sure it is equipped with the latest in modern technology for added performance and durability.

### **READ THIS MANUAL THOROUGHLY**

Before starting your engine(s), READ THIS MANUAL CAREFULLY AND COMPLETELY. If you do not understand any portion of the manual, contact your Dealer for clarification or assistance. Ask your Dealer for a demonstration of actual starting and operating procedures.

The descriptions and specifications contained in this manual were in effect at the time of printing. PCM Engines' policy of continued improvement reserves the right to change specifications or design without notice and without obligation.

This manual will cover the following PCM engines:

<b>Year</b>	<b>Model</b>
<b>2004</b>	<b>5.0L MPI</b>
<b>2004</b>	<b>5.7L MPI</b>
<b>2004</b>	<b>6.0L MPI</b>
<b>2004</b>	<b>8.1L MPI (Python)</b>

# TABLE OF CONTENTS

<b>INTRODUCTION</b> .....	<b>3-5</b>
Registration Information (Warranty Registration Card is located at the back of this manual) .....	3
3-Year Transferable Limited Warranty .....	4
California Emission Control Warranty Statement .....	5
PCM Model Years 2003-2008 General Emissions Warranty Coverage .....	6
Safety Information .....	9
Replacement Parts .....	9
Safety Warnings .....	9
<b>BOATING RESPONSIBILITY</b> .....	<b>10-12</b>
Carbon Monoxide Hazard .....	10
Safe Boating Suggestions .....	11
Water Wisdom .....	11
Operation and Maintenance .....	11
Rules of the Road .....	12
<b>ENGINE IDENTIFICATION</b> .....	<b>13-14</b>
Engine Identification .....	13
Owner Identification and Registration Information .....	13
2004 Model Identification / Advisory .....	14
<b>ELECTRONIC FUEL INJECTION INFORMATION</b> .....	<b>15</b>
Electronic Fuel Injection System .....	15
Power Reduction Mode .....	15
<b>OPERATING INSTRUCTIONS</b> .....	<b>16-20</b>
Engine Alarm System .....	16
Instrumentation .....	17
Starting Engine (Fuel Injected Engines) .....	18
Shifting Transmission .....	19
Stopping Engine .....	20
Freezing Temperature Operation .....	20
Operation in High Debris Areas .....	20
<b>CONDITIONS AFFECTING OPERATION</b> .....	<b>21-22</b>
Trim and Weight Distribution .....	21
Boat Bottom .....	21
Propeller Selection .....	22
<b>ENGINE BREAK-IN PERIOD</b> .....	<b>23</b>
<b>25-HOUR ENGINE INSPECTION</b> .....	<b>24</b>
<b>FUEL REQUIREMENTS</b> .....	<b>25</b>
Gasoline Requirements .....	25
Gasoline Containing Alcohol .....	25
<b>OIL REQUIREMENTS</b> .....	<b>26</b>
Engine Oil Recommendations .....	26
Transmission and "V"-Drive Oil Requirements .....	26
<b>ENGINE MAINTENANCE</b> .....	<b>27-55</b>
Engine Maintenance .....	27



# TABLE OF CONTENTS

---

Checking Fluid Levels .....	27-28
Lubrication .....	29
Electrical System Circuit Breaker(s) .....	30
Electrical System Fuses .....	30
Ignition Fuse .....	30
Electrical System Wiring and Connectors .....	30
Battery .....	31
Fresh Water Cooling System Sacrificial Zinc Anode .....	32
Checking Coolant Level .....	33
Flushing Cooling System - Sea-Water Section .....	34
Testing Coolant For Alkalinity .....	35
Draining Fresh-Water Cooling System .....	35
Filling Fresh-Water Cooling System .....	36
Cleaning Sea-Water Section of Heat Exchanger (Fresh-Water Cooled Applications Only) .....	37
Fuel System Description .....	38
Fuel Control Cell (FCC) Fuel System .....	38
Servicing the FCC .....	39
Draining the FCC Bowl, ENGINE OFF .....	40
Filter Element Replacement, ENGINE OFF .....	40
Primary Fuel Filter .....	41
Priming Fuel System .....	42
Flame Arrestor .....	42
Accessory Drive Belt .....	43-46
Changing Oils .....	47
Engine Alignment .....	47-50
Engine Maintenance Log .....	51
Maintenance Schedule .....	52
Visual Inspection .....	54
Engine Fluid Capacities .....	54
Transmission Fluid Capacities .....	54
Filter Requirements .....	55
<b>ENGINE SPECIFICATIONS .....</b>	<b>56-58</b>
<b>OUT-OF-SEASON STORAGE .....</b>	<b>59-62</b>
Engine Storage .....	59
Draining Instructions .....	60
Battery Storage .....	61
Recommissioning After Storage .....	62
<b>TROUBLESHOOTING .....</b>	<b>63-65</b>
<b>WATER FLOW DIAGRAMS .....</b>	<b>66-71</b>
<b>INSTRUMENTATION WIRING DIAGRAM .....</b>	<b>72</b>
<b>LITERATURE .....</b>	<b>73</b>
<b>FORMS.....</b>	<b>74-77</b>
<b>NOTES .....</b>	<b>78</b>



## REGISTRATION INFORMATION

**(Warranty Registration Card is located at the back of this manual)**

Shortly after your purchase is registered with PCM, you will be mailed your Warranty Card and a Customer Survey. We appreciate your feedback and encourage you to fill out the survey after you have had a chance to run your boat for several weeks. We take this input very seriously, and have implemented many of the ideas our customers have given us through this survey. You may also visit our web site at [www.pleasurecraft.com](http://www.pleasurecraft.com).

Again, thanks for choosing PCM. We sincerely wish you happy days on the water.



# INTRODUCTION - 1

## 3 Year Transferable Limited Warranty

Pleasurecraft Marine Engine Co. (PCM) warrants its new products to be free from defects in material and workmanship under normal use and service conditions, to the first registered user, and all subsequent user who, in accordance with PCM's warranty transfer policy, transfers any remaining portion of this warranty coverage within 30 days of any subsequent sale/purchases. All components of PCM products are covered under the PCM Warranty, except for those components that are warranted by PCM's suppliers. The obligation of PCM hereunder shall be limited to the repair or replacement with new or remanufactured components, at its option, of any product or parts thereof which has failed during the period of warranty and which is demonstrated upon examination to have failed due to defective material and/or workmanship.

PCM's policy is one of continued improvement of its products and PCM hereby reserves the right to improve and change the design and production of any of its products without assuming any obligation to modify products previously manufactured and/or sold.

### NO OTHER WARRANTY GIVEN

The obligations set forth in the preceding paragraph are PCM's sole obligation and owner's exclusive remedy. PCM makes no other express warranty to the extent that any additional warranty may be implied by law, the term of such implied warranty shall be limited to the warranty term stated herein, from the date of delivery of the PCM product to the parties outlined herein.

No distributor, dealer, agent or employee of PCM is authorized to grant any other or further warranty or incur any additional warranty obligation on PCM's behalf, in connection with the sale of its products. Any qualification or restriction contained herein which is prohibited by any law of mandatory application shall be deemed to be deleted herefrom, however, such deletion shall have no effect on the remaining provisions hereof, all of which shall remain full force and effect.

### REMEDIES

The obligations of PCM set forth in the first paragraph of this Warranty shall be the exclusive remedy for any breach of Warranty hereunder, and any owner or user's sole remedy in the event of breach of the warranties which are made by PCM is repair or replacement of the product or any warranted part thereof as set forth herein: **with this sole exception, PCM shall not be liable for any direct, or indirect, incidental or consequential damages**, including without limitation, any damages for property damage, loss of use or loss of profits, loss of income, inconvenience, trailering, towing, haul out, launch and/or any other in and out of water expenses, storage charges, dockage charges, expenses to deliver or pick up the product being warranted to and from the dealer, telephone expenses, lodging expenses, travel expenses, mechanic travel time and mileage, damage caused by any occurrence of an insurable nature, rental of substitute equipment of any type, removal and replacement and/or modification of any boat parts to facilitate repairs, moving of furniture, carpets, cleaning, painting, carpenter work, or re-delivery charges.

Some States do not allow limitations on how long an implied warranty lasts, so the above limitations may not apply to you.

Some States do not allow the exclusion or limitation of incidental or consequential damages, so the above limitation or exclusion may not apply to you.

**Any owner or user hereby waives for himself/herself/itself and his/her/its successor and assigns (a) any and all claims for punitive damages, and (b) all claims of negligence or strict liability or both, In no event will PCM's liability exceed the purchase price of the goods which is actually paid to PCM.**

### WARRANTY COVERAGE, TERM

This Warranty is extended only to the first registered owner or registered user, and all subsequent user who, in accordance with PCM's warranty transfer policy, transfers any remaining portion of this warranty coverage within 30 days of any subsequent sale/purchases, for the period specified below:

All components, other than and those itemized below, are warranted for a period of three (3) years from the date of delivery to the first registered owner or registered user, and all subsequent user who, in accordance with PCM's warranty transfer policy, transfers any remaining portion of this warranty coverage within 30 days of any subsequent sale/purchases in non-commercial use. In case of commercial use, the term of this Warranty shall be the shorter of (a) a period of six (6) months from the date of delivery to the first registered owner or registered user or (b) the expiration of 200 hours of use.

Items not covered under this warranty;

(A) Water pump impellers are not covered by this Warranty.

(B) Seals, gaskets, O-rings, and other material affected by time are not covered by this Warranty if their effectiveness is reduced by an extended storage period prior to sale or use.

### OBTAINING PERFORMANCE UNDER WARRANTY

PCM's warranty registration form should be prepared by your selling dealer, executed by you and the dealer and mailed, by you, to PCM within 30 days after the date of purchase. Upon receipt of the warranty registration form, PCM will issue to you a personalized owner's registration card which will be mailed directly to you. If the owner's registration card is not received within eight (8) weeks after the date of purchase, please write PCM at the address below.

At the time that a claim for warranty service is made, the owner's registration card should be presented to the person or entity providing warranty service. Authorized PCM dealers or distributors are entitled to be reimbursed by PCM for some or all of the expense of warranty repairs, thus, service under the terms of this Warranty will be performed by an authorized PCM dealer or distributor without charge for established flat rate labor or replacement parts, other than items not covered by the Warranty, such as , but not limited to, lubricants, spark plugs, points, and other items which are normally frequently replaced as part of routine maintenance. Charges for additional non-warranty work and/or additional dealer charges for labor relative to warranty work in excess of flat rate must be paid for by the owner.

Prior authorization in writing must be obtained from PCM for any warranty repairs over \$50.00 and in all cases where the owner fails to establish the purchase and warranty expiration dates with the owner's registration card sent upon receipt of the warranty registration form by PCM. While failure to present the owner's registration card will not prevent you from obtaining coverage hereunder, this Warranty shall not be effective and, therefore, cannot be honored until the product purchase date can be confirmed by PCM. If the card is lost, communicate with PCM at the address listed below, and, for a processing fee of \$10.00, a new owner's registration card will be issued to you.

Any questions concerning service, parts or this Warranty should be directed to your selling dealer. If your dealer is unable to assist or if you relocate or are travelling or need a referral to your nearest dealer contact: Pleasurecraft, P.O. Drawer 369, Little Mountain, SC 29075

### FAILURES EXCLUDED FROM WARRANTY

This Warranty will not apply to any failure which results from accidents, sinking, fire, neglect, abuse, or abnormal service or use, such as racing, towing or operation in water of insufficient depth, or to any failure resulting from improper installation, improper adjustments, repairs or improper delivery service, or to any failure resulting from the use of parts, fuels, oils or lubricants not suitable for use with the product and/or materials or parts not approved by PCM. This Warranty does not apply to any engine or drive which has been modified, or altered, or repaired in such a manner as, in the opinion of PCM, to affect its stability, reliability or performance. Further, this Warranty will not apply to failure resulting from use of non-recommended lubricants or fuels, failure to follow maintenance or lubrication schedules, failure caused or contributed to by contaminated fuel, failure caused by improper installation or misapplication of the engine or drive, failure resulting from the owner's or operator's failure to exercise due or normal care and precaution, or failure of components and/or assemblies that are warranted by PCM suppliers.

### OWNER'S RESPONSIBILITY

Performance under this Warranty shall be conditioned upon the first registered owner's or registered users' compliance with the following requirements:

- 1 Owner or user shall verify that the pre-delivery service has been performed, all requested information recorded and that the selling dealer has signed the warranty registration.
- 2 Owner or user shall promptly mail the warranty registration to PCM after accepting delivery.
- 3 Owner or user shall follow the instruction in the owner's manual regarding operation, break-in, lubrication, and fuel.
- 4 Owner or user shall follow or comply with the maintenance schedule, operation limits, and lay up instruction, as outlined in the owner's manual.

### CHOICE OF LAW

This Limited Warranty shall be governed by, and construed and interpreted in accordance with, the laws of the State of Ohio, except only to the extent replaced or precluded by other law of mandatory application.

### SPECIAL STATE LEGAL REQUIREMENTS

This Warranty gives you specific legal rights, and you may also have other rights which vary from State to State.

The PCM California Model Years 2003-2008 Emissions Warranty and California Emissions Control Warranty Statement is a separate document included in this Manual. Any questions concerning the Emissions Warranty can be obtained by calling 1-803-345-0050.

## CALIFORNIA EMISSION CONTROL WARRANTY STATEMENT YOUR WARRANTY RIGHTS AND OBLIGATIONS

The California Air Resources Board and Pleasurecraft Marine Engine Co. (hereinafter "Pleasurecraft") are pleased to explain the emission control system warranty on your Model Years 2003-2008 inboard engine. In California, new inboard engines must be designed, built and equipped to meet the State's stringent anti-smog standards. Pleasurecraft must warrant the emission control system on your inboard engine for the periods of time listed below provided there has been no abuse, neglect or improper maintenance of your inboard engine.

Your emission control system may include parts such as the carburetor or fuel injection system, the ignition system, and catalytic converter. Also included may be hoses, belts, connectors and other emission-related assemblies.

Where a warrantable condition exists, Pleasurecraft will repair your inboard engine at no cost to you, including diagnosis, parts and labor.

### **MANUFACTURER'S WARRANTY COVERAGE:**

Select emission control parts from Model Years 2003-2008 inboard engines are warranted for 2 years.

### **OWNER'S WARRANTY RESPONSIBILITIES:**

- As the inboard engine owner, you are responsible for the performance of the required maintenance listed in your owner's manual. Pleasurecraft recommends that you retain all receipts covering maintenance on your inboard engine, but Pleasurecraft cannot deny warranty coverage solely for the lack of receipts or your failure to ensure the performance of all scheduled maintenance.
- As the inboard engine owner, you should however be aware that Pleasurecraft may deny you warranty coverage if your inboard engine or a part has failed due to abuse, neglect, improper maintenance or unapproved modifications.
- You are responsible for presenting your inboard engine to a Pleasurecraft distribution center as soon as a problem exists. The warranty repairs will be completed in a reasonable amount of time, not to exceed thirty (30) days.

If you have any questions regarding your warranty rights and responsibilities, you should contact Pleasurecraft at 1-803-345-0050.



# INTRODUCTION - 1

---

## PLEASURECRAFT MARINE ENGINE CO. MODEL YEARS 2003-2008 GENERAL EMISSIONS WARRANTY COVERAGE

1. Pleasurecraft Marine Engine Co. (hereinafter referred to as "Pleasurecraft") warrants to the first owner purchasing at retail, and all subsequent owners, of every Pleasurecraft Model Years 2003-2008 inboard engine that the emissions control devices on Pleasurecraft inboard marine engines are free from defects in materials and workmanship when manufactured and will remain so for a period of two (2) years from the date of delivery to the first owner purchasing the engine at retail or from the date the engine is first placed into service for demonstration or any other purpose prior to sale to the first owner purchasing the engine at retail.
2. Pursuant to the California Code of Regulations Title 13, Chapter 9, Article 4.7§ 2445.1, Pleasurecraft warrants that each Pleasurecraft engine is designed, built and equipped to conform with all applicable regulations adopted by the California Air Resources Board pursuant to its authority in Chapters 1 and 2, Part 5, Division 26 of the Health and Safety Code, and is free from defects in materials and workmanship that cause the failure of a warranted part to be identical in all material respects to that part as described in Pleasurecraft's application for certification.
3. Any part covered under this Warranty that is not scheduled for replacement as required maintenance, in the written instructions to be found within the Pleasurecraft Owners/Operators Manual, is warranted for the period of two (2) years. If the part fails during the period of warranty coverage, Pleasurecraft will repair or replace the defective part at any Pleasurecraft warranty station. The repair or replacement will be performed at no charge to the owner. Any such part repaired or replaced under this Warranty will be warranted for the remainder of the two (2) year period.
4. Any part covered under this Warranty that is scheduled only for regular inspection in the written instructions to be found within the Pleasurecraft Owners/Operators Manual, is warranted for the period of two (2) years. If the part fails during the period of warranty coverage, Pleasurecraft will repair or replace the defective part at any Pleasurecraft warranty station. The repair or replacement will be performed at no charge to the owner. Any such part repaired or replaced under this Warranty will be warranted for the remainder of the two (2) year period.
5. Any part covered under this Warranty that is scheduled for replacement as required maintenance in the written instructions to be found within the Pleasurecraft Owners/Operators Manual will be warranted for the period of time before the first scheduled replacement date for that part. If the part fails before the first scheduled replacement, Pleasurecraft will repair or replace the defective part at any Pleasurecraft warranty station. The repair or replacement will be performed at no charge to the owner. Any such part repaired or replaced under this Warranty will be warranted for the remainder of the period prior to the first scheduled replacement date for the part.
6. Replacement of any part under this Warranty with a Pleasurecraft supplied part, will not shorten nor extend the warranty period(s) stated in paragraphs one (1) thru four (4) above.
7. The engine owner will not be charged for diagnostic labor that is directly associated with diagnosis of a defective, emission-related warranted part, provided that such diagnostic work is performed at a Pleasurecraft warranty station.



8. To insure prompt repair under this Warranty, Pleasurecraft will maintain a supply of warranted parts sufficient to meet the expected demand for such parts. Any replacement part may be used in the performance of any warranty maintenance or repairs and will be provided by Pleasurecraft without charge to the owner.
9. Parts covered under this Warranty are: spark plugs, spark advance/retard system, ignition coil and/or control module, ignition wires, PCV valve, oil filler cap, intake valve(s), intake manifold, exhaust manifold, exhaust valve(s) hoses, clamps, fittings, tubing, sealing gaskets or devices, and mounting hardware, pulleys, belts and idlers, temperature check, and valves and switches, and electronic controls.
10. Exclusions: The repair or replacement of any warranted part otherwise eligible for coverage under this Warranty may be excluded from such warranty coverage if Pleasurecraft demonstrates that the engine and/or part has been abused, neglected, or improperly maintained, and that such abuse, neglect, or improper maintenance was the direct cause of the need for repair or replacement of the part.
11. Pleasurecraft original equipment parts are "identical in all material respects to that part as described in the engine manufacturer's application for certification". The use of any replacement parts not supplied by Pleasurecraft may not meet this requirement and will be grounds for disallowing a claim made under this Warranty. Pleasurecraft will not be liable under this Warranty or provide warranty coverage for product failures caused by parts other than Pleasurecraft original equipment parts.
12. If you have any questions regarding your warranty rights and responsibilities, or the location of Pleasurecraft warranty stations near you, you should contact Pleasurecraft at 1-803-345-0050.



**This Page Was  
Intentionally  
Left Blank**

## SAFETY INFORMATION

“Safety Warnings” and additional information or instructions are used to alert the installer/operator of possible safety hazards in performing certain service or maintenance procedures incorrectly or carelessly. DANGERS and WARNINGS are accompanied by the international HAZARD symbol: 

These “Safety Warnings” alone cannot eliminate the hazards that they signal. Strict compliance with these warning instructions while performing service and maintenance procedures, plus “common sense” operation, are major accident prevention measures.

## REPLACEMENT PARTS



### DANGER

Electrical, ignition and fuel system components are designed and manufactured to comply with U.S. Coast Guard rules and regulations to minimize the possibility of fire or explosion hazard.

Use of replacement parts (i.e. automotive, after-market, etc.) in the electrical, ignition and fuel systems, which are not U.S. Coast Guard approved, could cause a fire or explosion hazard and should be avoided.

Always request that genuine PCM Engines replacement parts be used in any repairs or maintenance being performed on your engine(s).

## SAFETY WARNINGS



### DANGER

Signals serious damage, failure or breakdown of equipment; severe injury or high probability of death to the user if proper precautions are not taken. This signal word is applied in extreme situations



### WARNING

Indicates a potential hazard which could result in personal injury.



### CAUTION

Indicates a hazard which could result in damage to equipment.

**IMPORTANT:** or **IMPORTANT:** Used to provide information to perform a procedure more easily.

**WARRANTY NOTICE:** Indicates a possible warranty exclusion.

# BOATING RESPONSIBILITIES - 2

## CARBON MONOXIDE HAZARD



### DANGER

**Carbon Monoxide (CO) is a colorless, odorless and tasteless gas. You cannot see it, smell it or taste it. Prolonged exposure to carbon monoxide can lead to unconsciousness, brain damage or death!**

Carbon monoxide is produced when anything that contains carbon, such as gasoline, natural gas, oil, propane, coal or wood is burned. Carbon monoxide is commonly found in the exhaust of internal combustion engines (boat power plants, generators, etc.). In addition, open flame devices like cooking ranges, heaters and charcoal grills also produce carbon monoxide.

Carbon monoxide accumulation, in and around boats is affected by vessel geometry; overall vessel design; closeness to other structures; wind direction; boat speed; and many other variables. In no way can this section cover all of the possible variables. Do not rely on this section as the exclusive listing of measures to prevent the accumulation of carbon monoxide.

Consult your boat operators manual for detailed information on the inspection and/or maintenance of the exhaust system for your particular application. If an inspection reveals possible leaks, DO NOT operate your engine(s) until it can be serviced by a qualified technician.

Proper and adequate air circulation, around and throughout the boat, is absolutely necessary to aid in the prevention of carbon monoxide build-up. If you have any questions or concerns regarding the operation of your boat and carbon monoxide hazards, DO NOT operate your engines until you have contacted your boat manufacturer.

To find out more about making boating safer, including how you can prevent carbon monoxide poisoning on recreational boats, contact:

### **National Marine Manufacturers Association**

200 East Randolph Drive  
Suite 5100  
Chicago, IL 60601-6528  
[www.nmma.org](http://www.nmma.org)  
312-946-6200

### **United States Coast Guard**

Office of Boating Safety  
CG Headquarters G-OPB-3  
2100 Second Street SW  
Washington, DC 20593  
[www.uscgboating.org](http://www.uscgboating.org)  
202-267-0984

### **American Boat & Yacht Council, Inc.**

3069 Solomon's Island Road  
Edgewater, MD 21037-1416  
[www.abyc.com](http://www.abyc.com)  
410-956-1050

## SAFE BOATING SUGGESTIONS

The nation's waterways are becoming increasingly crowded and, in order to enjoy them safely, the operator should acquaint himself/herself with safe boating practices. Boating safely and seamanship courses are offered by the following national and state organizations:

- Power Squadrons
- Coast Guard Auxiliary
- Red Cross
- State, provincial or local agencies in charge of water safety enforcement

PCM Engines highly recommends that all power boat operators attend one of these courses. To help locate a course being offered near you, contact Boat U.S. Foundation's toll-free national boating safety hotline, 1-800-336-BOAT, and in Virginia, 1-800-245-BOAT.

## WATER WISDOM

The following are suggestions for safe operation of your boat to ensure the safety of yourself and your passengers:

- Know your boat's loading and operating limitations. **DO NOT OVERLOAD!**
- Make periodic checks of safety equipment onboard.
- Do not consume alcoholic beverages or take illegal drugs when operating a boat. Some state laws apply to boats as well as motor vehicles.
- File a "float plan." Let someone know your destination and your expected time of return.
- Monitor the weather. Know the signs of weather change and avoid severe weather and rough seas whenever possible.
- Follow the "Rules of the Road" when boating. Always be on the alert and watch out for "the other guy."
- Plan and chart your course. Be aware of, and avoid, hazardous areas.
- Be sure your boat is equipped with the required safety equipment. Check with the Coast Guard and local government agencies as to the regulations and restrictions in your area. Contact your local Coast Guard Auxiliary and take advantage of their seasonal boat inspections.

The following is a list of suggested safety equipment and spare parts which may be useful in case of an emergency:

- Approved personal flotation devices (life jackets); one for each person on board.
- Approved throwable personal flotation device for man-overboard protection.
- Approved fire extinguishers.
- Signal devices: flares, spotlight, signal flag and horn or whistle.
- PCM Engines' "Onboard Kit," plus spare fuses, bulbs, batteries, etc. Tools necessary for minor repairs.
- Spare propeller.
- Anchor and anchor line.
- First aid kit and first aid book.
- Ship-to-shore radio, compass and chart of the area in which you are traveling.
- Manual bilge pump and spare drain plugs.
- Waterproof storage containers.

## OPERATION AND MAINTENANCE

It is the owner's/operator's responsibility to perform all safety checks before operating his/her boat. All lubrication and maintenance schedules must be adhered to assure optimum performance and dependability from your PCM engine. When service and maintenance are required, return to your authorized PCM Engine Dealer.



# BOATING RESPONSIBILITIES - 2

## RULES OF THE ROAD

### Channel Buoy Guide

The color of the paint is the only characteristic which has the same meaning on all buoys. Red buoys always indicate the starboard side of the channel from seaward. (Red Right Returning)

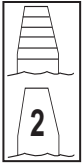

1. **Nun Buoy:** This buoy indicates the starboard side of the channel when returning from sea. It is conical shape, the color red and indicates even numbers. A nun buoy with red and green horizontal bands (top band red), and not numbered, indicates an obstruction. The principal channel is to the left of the buoy when returning from sea.

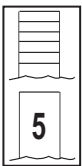



2. **Can Buoy:** This buoy indicates the port side of the channel when returning from sea. It is cylindrical shape, the color green and indicates odd numbers. A can buoy with green and red horizontal bands (top band green), and not numbered, indicates an obstruction. The principal channel is to the right of the buoy when returning from sea.

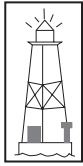

3. **Lighted Buoy (RED):** This buoy has a flashing red light. It indicates the starboard side of the channel when returning from sea.

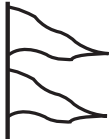

4. **Lighted Buoy (GREEN):** This buoy has a quick flashing green light. It indicates the port side of the channel when returning from sea. The quick flashing light indicates special caution required.

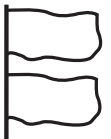
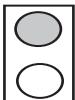
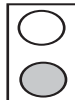
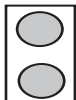
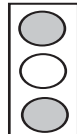
			
Small Craft Winds up to 38 MPH	Gale Winds 38 - 54 MPH	Storm Winds over 55 MPH	Hurricane Winds over 63 MPH
			

### Storm Warning Signals - Pennants (by day) Lights (by night)

### Boat Capacity

- Load only to manufacturer's specifications.
- Distribute load evenly; keep it low.
- Passengers should only ride on the parts of the boat that are designed for that purpose.
- If water is rough, carry fewer passengers.

### Observe the Rules of the Road

PORT (Left) - Leaving the harbor with green buoys to your right.

STARBOARD (Right) - Entering the harbor with red buoys to your right.

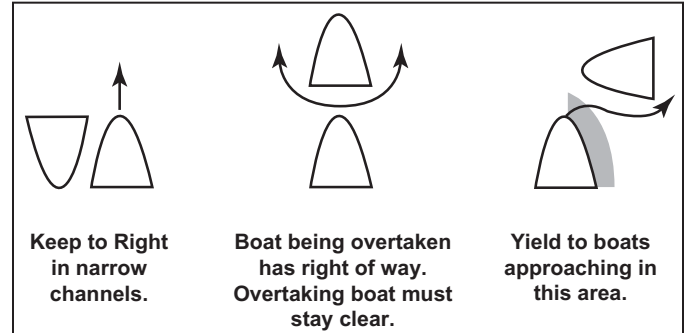

### Know Your Horn Signals

- 1 Short Blast = Passing you on my port side.
- 2 Short Blasts = Passing you on my starboard side.
- 3 Short Blasts = I am going astern.
- 5 Short Blasts = Danger.

**Always refer to the latest U.S. Coast Guard Navigation Rules CG-169**

### Keep An Alert Lookout For:

Bad weather, Swimmers, Other boats, Water skiers, Fisherman, Divers and/or any other obstructions.

**Keep Your Wake Under Control**, particularly upon entering or leaving harbor areas. You are responsible for wake damage to other vessels and/or property.

### Do Not Fool With Fuel

**1/2 pint of gasoline = 15 sticks of dynamite**

1. During fueling, moor boat properly; remove all passengers.
2. Keep all doors, hatches and ports closed.
3. Shut down all electronic gear; extinguish galley fires, pilot lights and smoking materials.
4. Do not overload tanks.
5. Keep filling nozzles in contact with the fill pipe to prevent sparks.
6. Secure the fill cap tightly; wipe away any spillage.
7. Ventilate all components for a minimum of five minutes before starting engines.
8. Keep fuel lines and bilges clean.

## ENGINE IDENTIFICATION

When ordering service parts or obtaining information, always give the engine model and the serial number. This information can be found on the following decal.

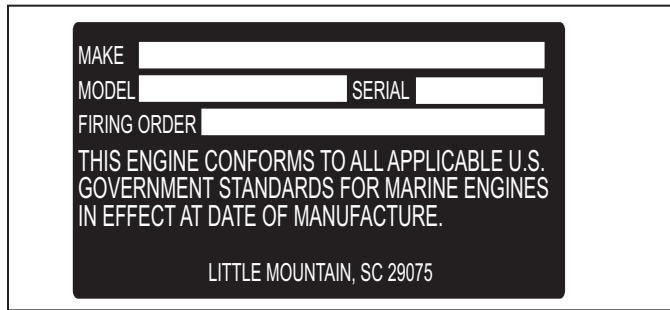

Figure 3-1 Engine Identification Decal

## OWNER IDENTIFICATION AND REGISTRATION INFORMATION

We suggest that you record the following information for quick reference when ordering parts or requesting service or warranty.

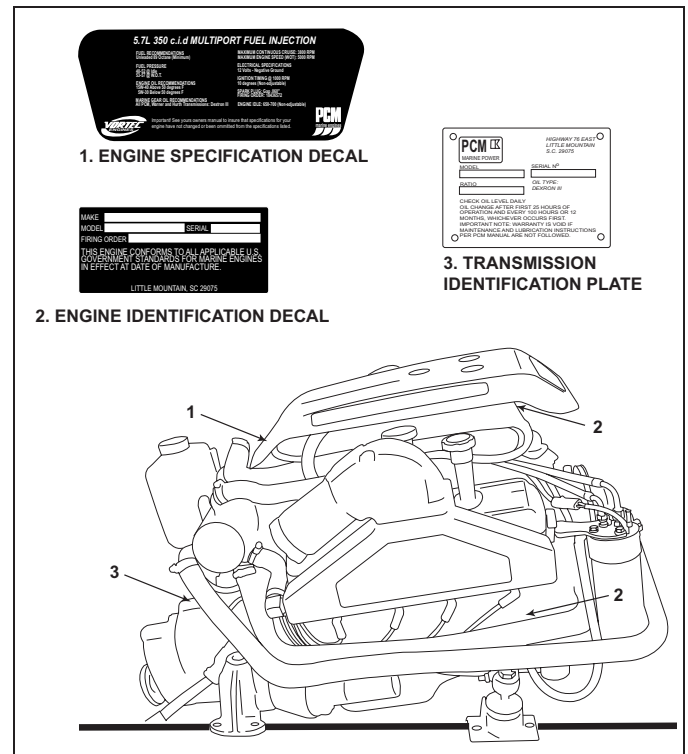

Figure 3-2 Engine Identification Tag Locations (5.0/5.7L)

	PORT	STARBOARD
<b>Engine Model Number:</b>		
<b>Serial Number(s):</b>		
<b>Gear Model Number:</b>		
<b>Serial Number(s):</b>		
<b>Boat Make:</b>		
<b>Boat Model:</b>		
<b>Hull Serial Number:</b>		
<b>Propeller Size:</b>		
<b>Ignition Key Number:</b>		

# ENGINE IDENTIFICATION - 3

## PCM

### 2004 MODEL IDENTIFICATION / ADVISORY

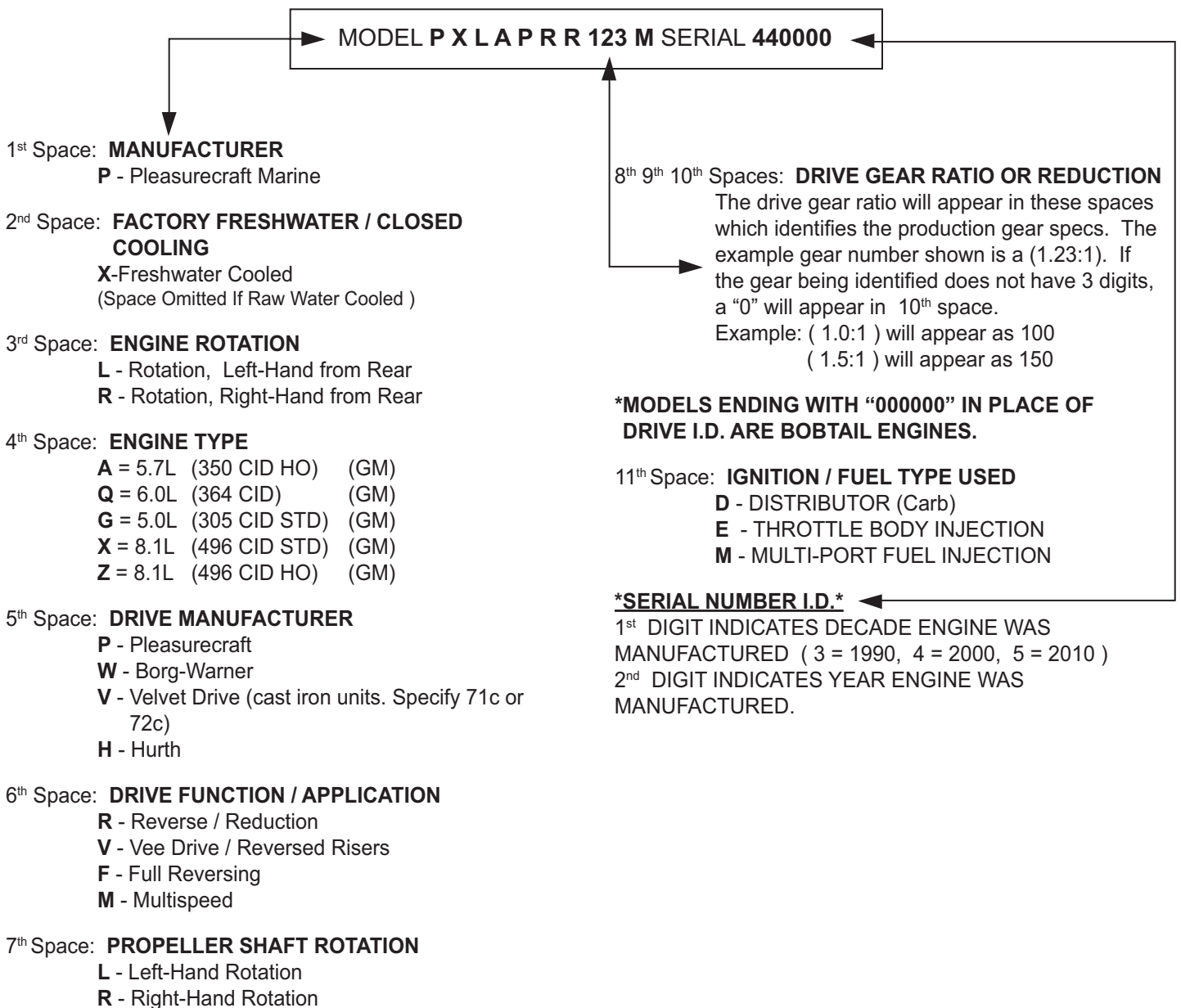



# ELECTRONIC FUEL INJECTION INFORMATION - 4

## ELECTRONIC FUEL INJECTION SYSTEM

The PCM engines covered in this manual are equipped with an Electronic Fuel Injection (EFI) system, which allows precise control of fuel and spark delivery. The fuel system components of the EFI system are:

- The electric fuel pump
- The throttle body assembly
- The fuel injectors

The fuel injection system is controlled by an Electronic Control Module (ECM). The ECM is the decision center of the system. The ECM constantly monitors information from various sensors on the engine, and electronically processes the information, in order to control ignition timing and fuel delivery for optimum performance and fuel economy. The ECM incorporates an engine overspeed protection, calibrated to a specific RPM, to prevent engine damage from over-revving.

The sensors that the ECM monitors are:

- Engine Coolant Temperature (ECT) Sensor
- Throttle Position (TP) Sensor
- Manifold Absolute Pressure (MAP) Sensor
- Knock Sensor (KS) System
- Crankshaft Positioning (CKP) Sensor
- Camshaft Positioning (CMP) Sensor
- Intake Air Temperature (IAT) Sensor

## POWER REDUCTION MODE

The ECM monitors engine oil pressure and engine coolant temperature whenever the engine is running. If either one of these inputs indicate an abnormal reading, the system will go into "Power Reduction" mode, followed by the illumination of an indicator lamp and/or sounding of the warning buzzer (if equipped). This is a feature that will help protect the engine during an over-temp or low oil pressure condition.

When in "Power Reduction" mode, the ECM will allow normal engine performance up to 2000 RPM. Above 2000 RPM, the ECM allows fuel delivery through only half of the fuel injectors. Once the RPM is brought down below 1200 RPM, normal engine operation is restored until the RPM exceeds 2000 RPM. The feature allows maneuverability of the boat while removing the possibility of high engine speed operation until the problem is corrected.

**NOTICE:** If it is not possible to safely shut off the engine, return the engine to idle speed. Once returned to idle, the ECM will allow the engine to operate normally below 2000 RPM.



# OPERATING INSTRUCTIONS - 5

---

## ENGINE ALARM SYSTEM (IF EQUIPPED)

The PCM engine electronic system is programmed to control the engine alarm system. This system utilizes an audible alarm and/or optional indicator lamps to warn the operator of possible engine problems, and that the engine have entered the "Power Reduction" mode as covered earlier in this manual.

The alarm has a "self" checking feature programmed into the system. This feature will sound the alarm for two short pulses upon initial start-up of the engine.

If the alarm sounds during operation, immediately throttle back to idle speed. Observe the indicator lamps to locate the problem circuit. The engine should be shut off to prevent damage to the engine.

**NOTICE:** Some boat builders may install their own alarm system. It is recommended that the boat owner check with his or her boat dealer for an explanation of the particular alarm system upon initial delivery.

## INSTRUMENTATION

Boat manufacturers install many different types of instrumentation on boats. Become familiar with the instrumentation on your boat and be aware of abnormal operating conditions. The following is a brief explanation of typical instrumentation found on most boats:

1. Tachometer - indicates the engine RPM (revolutions per minute)
2. Engine Synchronizer (twin engines only)
3. Water Temperature Gauge - indicates the engine coolant temperature
4. Oil Pressure Gauge - indicates the engine oil pressure
5. Voltmeter - indicates the battery voltage and charging system voltage
6. Hour Meter - indicates the engine operating time
7. Fuel Level Gauge - indicates the fuel tank level
8. Check Engine Lamp - indicates a problem with the engine control system

# OPERATING INSTRUCTIONS - 5

## STARTING ENGINE (FUEL INJECTED ENGINES)



### WARNING

Before starting engine, ventilate the engine compartment by operating the bilge blower for a minimum of five minutes to remove any gas fumes from the engine compartment. If the boat is not equipped with a blower, open the engine compartment hatches to ventilate and leave open while starting engine.

**IMPORTANT:** Do not start the engine without water being supplied to the sea water pick-up pump or sea-water pump impeller will be damaged, and subsequent overheating damage to the engine may result.

**IMPORTANT:** The following items should be checked before starting the engine, and each time the boat is operated:

- Fuel system for any signs of leakage
- Operation of remote controls and steering
- Engine and transmission oil levels
- Fuel tank levels
- Exhaust system for leaks and tightness of the clamps
- Battery connections and water level in battery cells
- Accessory drive belt(s)
- Cooling system for leaks. If equipped with fresh-water cooling, check coolant level in recovery bottle. Check for signs of water leaks at the exhaust manifolds, risers and elbows (Figure 5-2A). If the water is leaking externally, it is possible that the water is also leaking internally. This could result in internal engine damage. It is very important to service these maintenance items as soon as a problem is indicated.

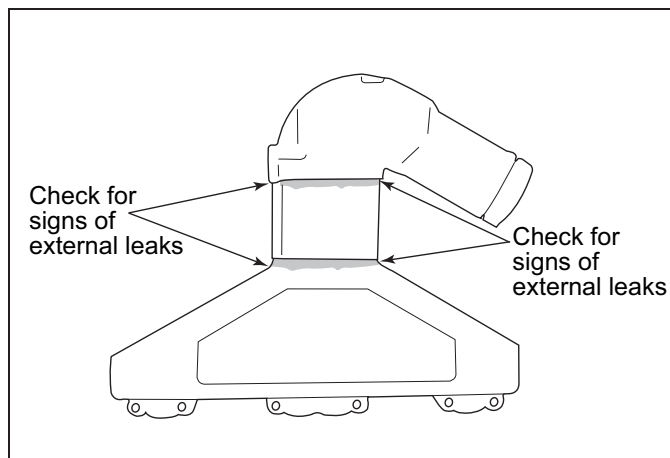
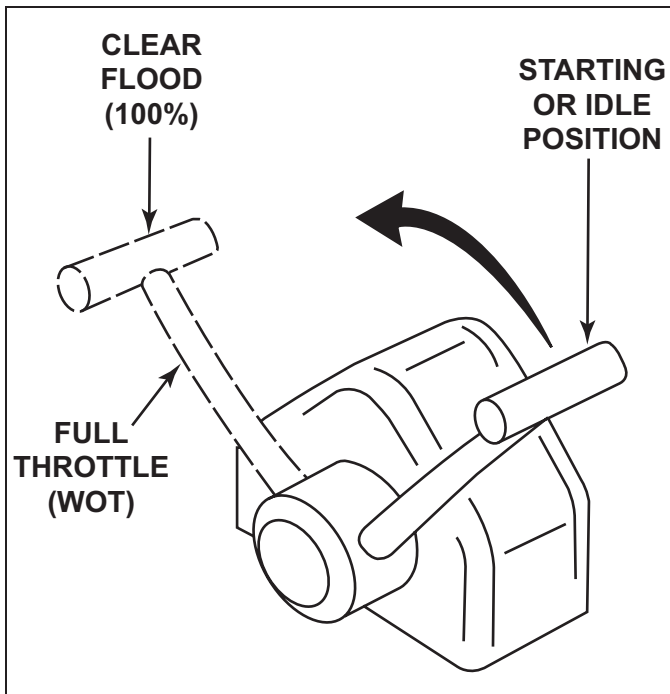

**Figure 5-2A** Water Leaks

After performing the initial safety checks, proceed as follows to start the engine:

1. Turn the battery switch ON (if equipped).
  2. Open the fuel valve.
  3. Open the seacock.
  4. Place the remote control in Neutral position. The transmission is equipped with a neutral safety switch, which will not allow the starter motor to operate unless the transmission is in neutral.
  5. Do not pump or open the throttle when starting the engine (Figure 5-1). The ECM will automatically regulate the fuel and control desired idle speed.
  6. Turn the ignition key to the start position. When the engine starts, release the key.
- NOTICE:** Engine idle speed is controlled by the ECM and is based on the operating temperature of the engine. Upon initial start-up, engine RPM will be slightly higher and will automatically decrease as the engine operating temperature increases.
7. **In the event the engine becomes flooded,** move the throttle lever to a 100% open position (Figure 5-1). At this throttle position, the ECM will command the injectors to deliver no fuel during engine cranking. When the engine starts, return the throttle lever back to the idle position.

**IMPORTANT:** If the engine fails to start within 20-30 seconds, turn the ignition key to the OFF position and allow 2 minutes for the starter motor to cool off before attempting to restart the engine.



**Figure 5-1** Throttle Position Setting

**NOTICE:** If engine still fails to start, contact your PCM Engines Dealer for service.

8. Check engine oil pressure immediately after the engine starts. If oil pressure is not within specifications (see Engine Specifications), immediately stop the engine and determine the cause.
9. Check voltmeter for proper charging system operation.
10. Check the engine and transmission for fuel, oil, water and exhaust leaks.
11. Allow the engine to reach normal operating temperature. Check the temperature gauge to ensure the engine is operating within the normal temperature range. If the temperature is abnormally high, stop the engine immediately and determine the cause.

## SHIFTING TRANSMISSION



### CAUTION

Never shift the transmission into or out of gear unless the throttle is at the idle position. Shifting the transmission above 1000 RPM can severely damage the boat, transmission and engine.

1. Set the throttle lever at the idle position.
2. Move the transmission lever **completely forward** to shift into Forward gear.
3. Move the transmission lever **completely backward** to shift into Reverse gear.
4. Move the transmission lever to the **center detent** position to shift into Neutral.

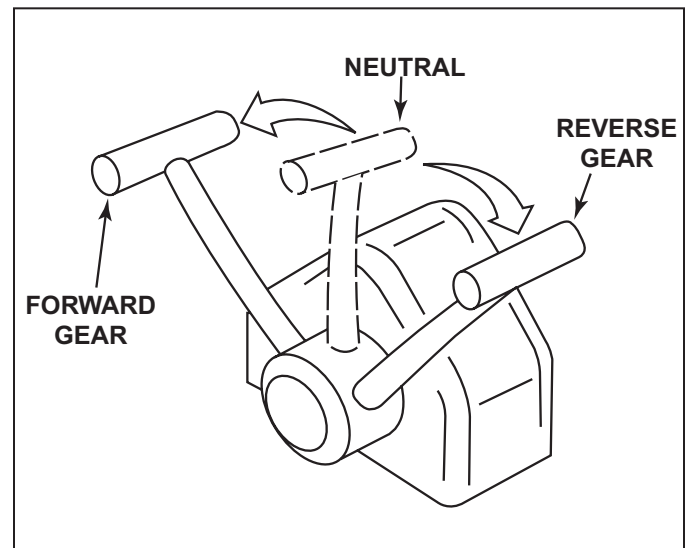

**Figure 5-2** Shift Control

# OPERATING INSTRUCTIONS - 5

---

## STOPPING ENGINE

When returning to the dock, or whenever stopping the engine, bring the throttle back to the idle position. After the engine reaches idle speed, turn the ignition key to the OFF position.

Before stopping the engine after extended high speed operation, allow the engine to idle at 1200 RPM for 3 to 5 minutes to allow the engine to cool down before shutting off the ignition.

After stopping the engine, complete the following:

1. Turn the battery switch OFF, if equipped.
2. Close the fuel valve.
3. Close the seacock.
4. Flush the cooling system if in a salt water area.

## FREEZING TEMPERATURE OPERATION

If the possibility of freezing exists, the cooling system must be protected after the engine is shut off to prevent freeze damage to the engine. Refer to OUT-OF-SEASON STORAGE for draining instructions.

## OPERATION IN HIGH DEBRIS AREAS

If the boat is to be operated in high debris areas, a sea strainer should be installed in the water inlet hose to prevent debris from entering the cooling system. The strainer used must be of sufficient size to allow an adequate supply of water for cooling the engine. A minimum of 30 gallons per minute (114 liters per minute) flow rate is required.

# CONDITIONS AFFECTING OPERATION - 6

## TRIM AND WEIGHT DISTRIBUTION

Trimming of the boat and positioning of the weight (gear and passengers) inside the boat has the following effects on handling:

- Trimming the bow up or shifting weight to the stern (rear).
  - Normally used for cruising (running) with a choppy wave condition (following sea) for running at full speed.
  - Will generally increase speed and engine RPM.
  - Will cause the bow to bounce in rough water.
  - In extreme, may cause the boat to porpoise.
  - When coming off plane, it increases the chances of following wave splashing into the stern of the boat.
- Trimming the bow down or shifting the weight to the bow (front).
  - Normally used for cruising (running) against a choppy wave condition, acceleration onto plane and operating at slow planing speeds.
  - Will improve rough water ride and handling.
  - In extreme, may cause the boat to bow steer (veer back and forth with little control).

## BOAT BOTTOM

To ensure maximum engine performance, fuel economy and boat speed, the bottom of your boat must be kept clean and free of marine growth and barnacles. Marine vegetation may accumulate when the boat is docked and should be removed before operation. If the boat is docked for long periods of time, the water inlets may become clogged with growth and will cause the engine to overheat.

In most areas, it is advisable to coat the boat bottom with antifouling paint to prevent the build-up of marine growth. Contact your dealer for advice on these requirements in your area.



# CONDITIONS AFFECTING OPERATION - 6

## PROPELLER SELECTION

Best all-around performance and maximum engine life is achieved when the engine is propped to run near the top of (but within) the recommended full throttle RPM range with a normal load. See ENGINE SPECIFICATIONS for rated full throttle RPM for your model engine.

Generally, gross weight (total weight of the entire boat, including full fuel and water, optional equipment, passengers and other miscellaneous gear) is one of the major factors and should be one of the primary considerations when selecting a propeller. Other factors to take into consideration are as follows:

- Warmer weather and higher humidity will cause an RPM loss.
- Operating the boat in a higher elevation will cause an RPM loss.
- Operating the boat with an increased load will cause an RPM loss (additional equipment, passengers, etc.).

If full throttle RPM is above or below the recommended range as stated in ENGINE SPECIFICATIONS, the propeller must be changed to prevent loss of performance. A one-inch change in either the pitch or diameter of a given propeller will generally change engine RPM by 150 to 250 RPM.

### ENGINE RPM CHART

Model	Minimum Full Load	Preferred	Maximum
MP 5.0L	4600	4800	5000
MP 5.7L	4800	5000	5200
MP 6.0L	4800	5200	5300
MP 8.1L (Python)	4800	5000	5200



### CAUTION

Prolonged WOT operation will shorten the life of your engine and could cause premature engine failure. See NORMAL CRUISING SPEEDS in SPECIFICATIONS. Problems caused by WOT operation are considered abuse and are not covered under the PCM Warranty.

**NOTICE:** These engines incorporate a RPM "REV LIMIT" in order to prevent the engine from over-revving.



# ENGINE BREAK-IN PERIOD - 7



## WARNING

Use this procedure **ONLY** when conditions are such that it can be done in complete safety.

The break-in period of your engine is the first 25 hours of operation. Proper engine break-in is essential to achieve maximum performance, longevity and minimum oil consumption. During the break-in period, the following operation guidelines must be adhered to:

- After the engine is thoroughly warmed up, and the boat is underway, open the throttle to wide open throttle until maximum RPM is reached. **DO NOT EXCEED MAXIMUM RPM.** (RPM should cease climbing after 10 to 20 seconds).



## CAUTION

**DO NOT** operate at full throttle in neutral at any time, or at sustained full throttle during the first 5 hours of operation. Thereafter, use sustained wide open throttle in the event of an emergency.

- Reduce the throttle to 2800 - 3000 RPM, and cruise at or below this speed for 1/2 hour. Reduce the speed to idle. Go to wide open throttle until maximum RPM is reached and operate for approximately 1 minute. Reduce throttle to 2800-3000 RPM and operate for a few minutes. (Bringing the engine speed from idle to wide open throttle will load the engine and assist in seating the piston rings). This cycle should be repeated from time to time during the first 5 hours of operation, but wide open throttle should not be sustained for more than 1 minute.
- During the remaining 20 hours of break in period, the engines can be run at cruise speeds that are approximately 75-80% of the wide open throttle RPM, occasionally varying the cruise speed by 100 RPM.
- During the early part of the break in period, the correct propeller selection can be confirmed. (With a normal load aboard, the engine's RPM should reach, but not exceed, the maximum RPM as listed in the specifications section).
- During the break in, all gauges should be watched carefully, and the speed should be reduced if abnormal readings become evident.



## CAUTION

**DO NOT** attempt to break in any engine by prolong idling, or running at the dock.

The engine oil level should be checked often and oil added when necessary. It must be understood that every internal combustion engine will use a certain amount of oil during operation to act as a lubricating and cooling agent, especially during the break-in period. Oil consumption should decrease and become stabilized after approximately 100 hours of operation.

At the end of your 25-hour break-in period, contact your dealer and have the recommended 25-hour inspection done.

**NOTICE:** PCM Engines assumes no responsibility for the costs related to the 25-hour inspection. This is the owner's responsibility.

# 25-HOUR ENGINE INSPECTION - 8

---

After the first 25 hours of operation, it is recommended that the engine be given an inspection. Your boat dealer or a PCM servicing dealer should be contacted to perform the necessary checks and adjustments to ensure the proper engine performance. The following maintenance should be performed:

- Change the engine oil and filter.
- Replace the primary fuel filter
- Check the engine alignment.
- Inspect the accessory drive belt(s) and check the tension.
- Check all the fluid levels.
- Check the throttle and the shift cable adjustments and check for freedom of movement.
- Cooling System - Inspect all the hoses for leaks, damage and deterioration. Check all the hose clamps for adequate tightness.
- Exhaust System - Inspect the entire exhaust system for leaks, damage and deterioration. Check all the hose clamps for adequate tightness.
- Battery - Check the electrolyte level and specific gravity. Inspect the case for damage. Check the battery cables and connections.
- Engine Assembly - Check for loose, missing or damaged parts. Pay close attention to engine mounts, starter and alternator mounting fasteners.

**NOTICE:** PCM Engines assumes no responsibility for the costs related to the 25-hour inspection. This is the owner's responsibility.

## GASOLINE REQUIREMENTS

**WARRANTY NOTICE:** Damage caused to the engine through the use of improper gasoline, low-quality or gasoline with an octane rating below the minimum requirements listed below, is considered misuse of the engine. Such damage is not covered by the PCM Engines warranty.

The ignition timing set by the factory requires the use of a high-quality lead-free regular gasoline with the following octane specification.

Pump Octane Number (R+M/2) (PUMP) - 87

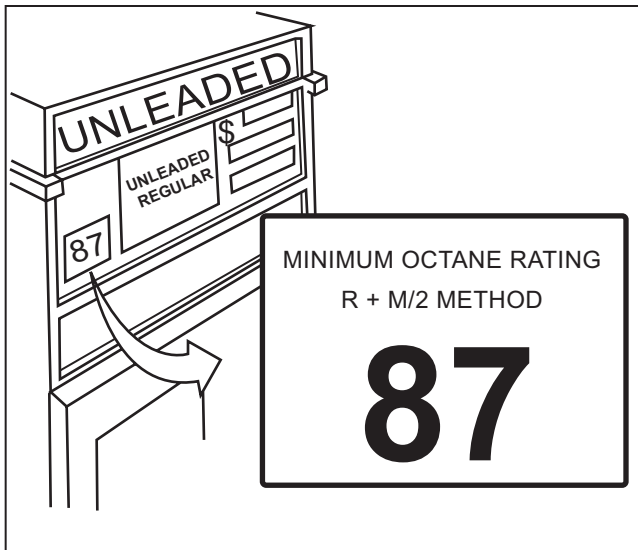

**Figure 9-1** Fuel Requirements

**NOTICE:** Most PCM Fuel Injected engines are calibrated to operate on 87 octane fuel and maximum performance is obtained when using this fuel. Some applications may require a higher octane fuel. These particular applications will be noted.

If a slight pinging is heard during acceleration and the proper octane fuel is being used, it is considered normal. If a constant, heavy knock occurs, the engine should be evaluated by a PCM Engine service technician.

## GASOLINE CONTAINING ALCOHOL

Gasoline containing alcohol, either ethanol (ethyl alcohol) or methanol (methyl alcohol) is not recommended for use in your engine. Gasoline containing alcohol will attract and hold moisture and may cause the following:

- Hard starting and operating difficulties (vapor lock, low speed stalling)
- Corrosion of metal parts
- Excessive wear and damage to internal engine parts
- Fuel permeation through flexible fuel lines
- Deterioration of some nonmetallic materials

The adverse effects of alcohol are more severe with methanol and are worse with increasing alcohol content.

If gasoline containing alcohol is used, or if the presence of alcohol is uncertain, more frequent inspections of the complete fuel system are required. Any sign of fuel leakage or deterioration must be repaired immediately before further engine operation.



### CAUTION

**Fire and Explosion Hazard** - Gasoline is extremely flammable and highly explosive, and, if ignited, can cause serious bodily injury or death. Careful inspection of the entire fuel system including, but not limited to, fuel tanks, fuel lines, fuel filters and all fittings is mandatory, especially after periods of storage. Replace any component that shows signs of leakage, corrosion, deterioration, swelling, hardening or softening.

**NOTICE:** Some gasolines contain an octane-enhancing additive called methylcyclopentadienyl manganese tricarbonyl (MMT), and they should not be used. These fuels may reduce spark plug life, and engine performance may be effected.

# OIL REQUIREMENTS - 10

## ENGINE OIL RECOMMENDATIONS

### Use of Supplemental Additives

Engine oils meeting PCM Engines' recommendations already contain a balanced additive treatment. The use of supplemental additives which are added to the engine oil by the customer are unnecessary and may be harmful. PCM Engines does not review, approve or recommend such products.

### Synthetic Oils

Synthetic engine oils are not recommended for use in PCM Engines. Synthetics may offer advantages in cold temperature pumpability and high temperature oxidation-resistance. However, synthetic oils have not proven to provide operational or economic benefits over conventional petroleum-based oils in PCM Engines. Their use does not permit the extension of oil change intervals.

### Engine Oil Requirements

The following chart shows the recommended oil viscosity for various ambient temperature ranges:

Prevailing Ambient Temperature	Recommended A.P.I. Classification & Viscosity
Above 50°F	SAE 15W-40 "SJ"
Below 50°F	SAE 5W-30 "SJ"

**IMPORTANT:** The use of oils which contain "solid" additives, non-detergent oils or low quality oils specifically are not recommended.

**WARRANTY NOTICE:** PCM Engines reserves the right to refuse warranty on part(s) and/or engine(s) damaged by using improper fuels and engine oils.

### Oil Change Intervals (Common)

Crankcase oil and oil filter change - Recommended intervals:

- Initial oil change - 1st 60 days or 25 hours of operation, whichever occurs first
- Regular oil changes - Every 50 hours of operation or 120 days, whichever occurs first

## TRANSMISSION AND "V"-DRIVE OIL REQUIREMENTS

Transmission and "V" Drive	Recommended A.P.I. Classification and Viscosity
PCM Transmissions	Dexron III Automatic Transmission Fluid (ATF) or equivalent
Walters "V"-Drive	SAE 30
All Hurth Gear Transmissions	Dexron III Automatic Transmission Fluid (ATF) or equivalent

## ENGINE MAINTENANCE

Refer to the MAINTENANCE SCHEDULE for a complete listing of required maintenance and the frequency at which it should be performed. Some procedures may be performed by the owner/operator while others should be performed by an authorized PCM Engines Dealer. Before performing any maintenance or repair procedure not covered in this manual, it is strongly recommended that a PCM Engines repair manual be purchased and read thoroughly.

## CHECKING FLUID LEVELS

### Engine Crankcase Oil



#### CAUTION

Do not overfill engine crankcase with oil, as excess oil will be splashed by reciprocating engine parts onto the cylinder walls in greater quantity than the rings can control. The oil, subsequently, will be drawn into the combustion chamber and burned. Continuous operation under these conditions can cause carbon to form on combustion chamber surfaces, which will adversely affect engine performance and may lead to premature engine failure. Splashing or agitation of oil also may cause it to become aerated, which will affect the oil pressure, and may result in internal engine damage from lack of lubrication.

1. Stop the engine if running. Allow approximately 5 minutes for the oil to drain back into the oil pan.
2. Remove the dipstick, wipe it clean, and reinstall it fully into the dipstick tube.
3. Remove the dipstick and observe the oil level. The oil level must be between the "FULL" and "ADD" marks. If the oil level is below the "ADD" mark, add specified oil to bring the level up to, but not over, the "FULL" mark on the dipstick. (Figure 11-1).

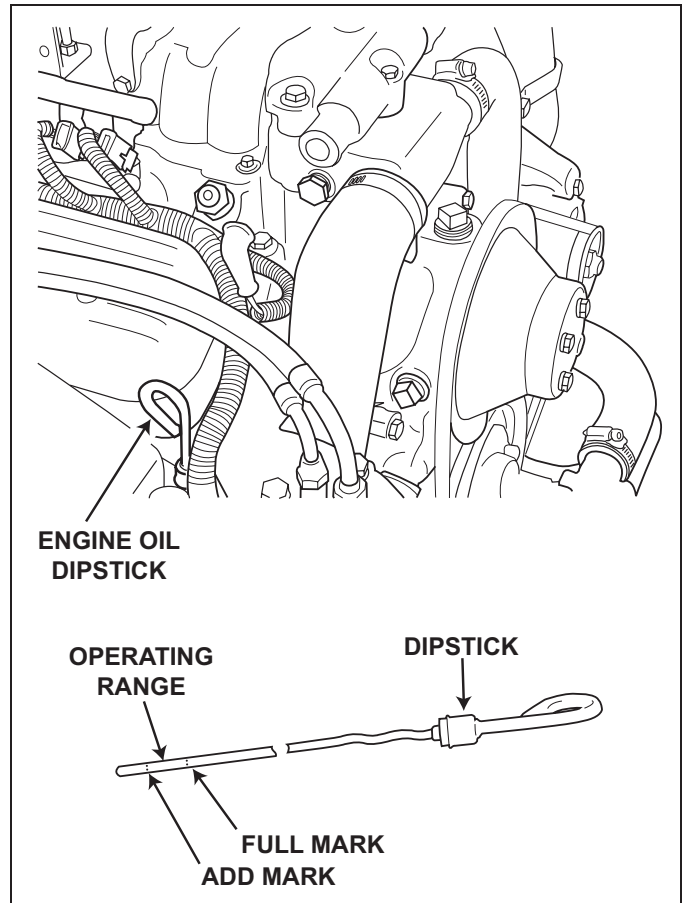

Figure 11-1 Engine Oil Dipstick (Typical)



#### WARNING

The machinery space must be closed anytime the engine is running to prevent injury to you or others on board. Never operate the engine with the engine machinery space open while someone is in the machinery space, either closed or open. Never open the machinery space unless the engine is shut off and the engines rotating parts are stationary. Rotating machinery can cause injury and even death if an accident should occur. Extreme care must be exercised if a problem exists that requires operation of the engine with the machinery space open. ***IT IS RECOMMENDED THAT UNCOVERED ENGINE OPERATION BE ATTEMPTED BY TRAINED AND QUALIFIED SERVICE PERSONNEL ONLY.***

# ENGINE MAINTENANCE - 11

## Transmission Fluid



### CAUTION

PCM Engines uses marine transmissions supplied by several manufacturers. The maintenance requirements can be different between these manufacturers. It is important that you refer to the operation and maintenance manual supplied by the transmission manufacturer before you attempt to perform maintenance on your own. If no maintenance manual is available, PCM Engines recommends that you contact your dealer service department for any required maintenance or service instructions.

### PCM Transmissions

1. Engine must be running at operating temperature.
2. Shift at least once into forward, once in reverse, then back to neutral.
3. With the engine running, and the prop shaft not turning, install the dipstick in all the way.
4. Remove the dipstick and check the fluid level. The dipstick should read FULL.
5. If the fluid level is low, add in small increments until the FULL mark is reached.
6. It is normal, after the engine is turned OFF, for the level to read above the FULL mark.

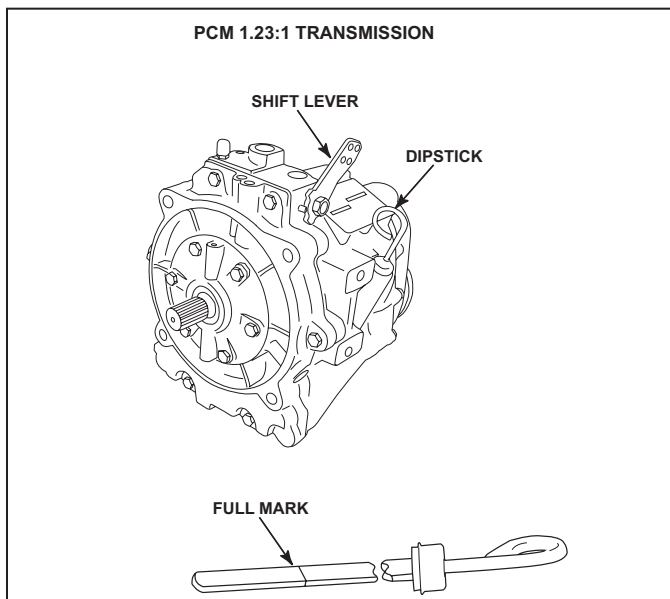

Figure 11-2 Transmission Dipstick and Location

## Hurth Transmission



### WARNING

Do not attempt to remove the transmission dipstick while the engine is running. Hot transmission fluid could be sprayed from the dipstick hole.

1. Remove the dipstick by turning the T-handle counterclockwise. Observe the fluid level. Replace the dipstick and tighten securely.
2. Operate the engine until the engine and the transmission reach operating temperature.
3. Stop the engine and quickly check the fluid level to minimize the drain-back from the oil cooler. Remove the dipstick by turning the T-handle counterclockwise. Observe the fluid level.
4. The fluid level should be at the "FULL" or "MAX" mark. If low, add the specified fluid through the dipstick tube. Repeat checking procedures as required until the fluid level is at the "FULL" or "MAX" mark.
5. Replace the dipstick and tighten securely.

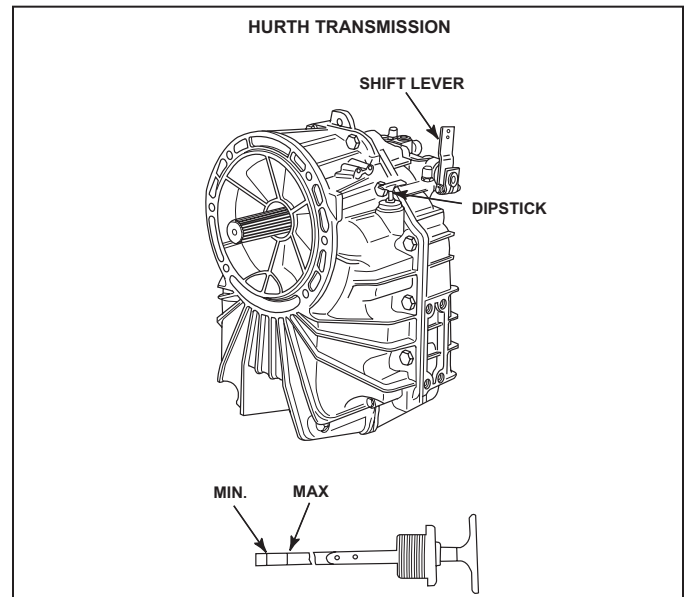
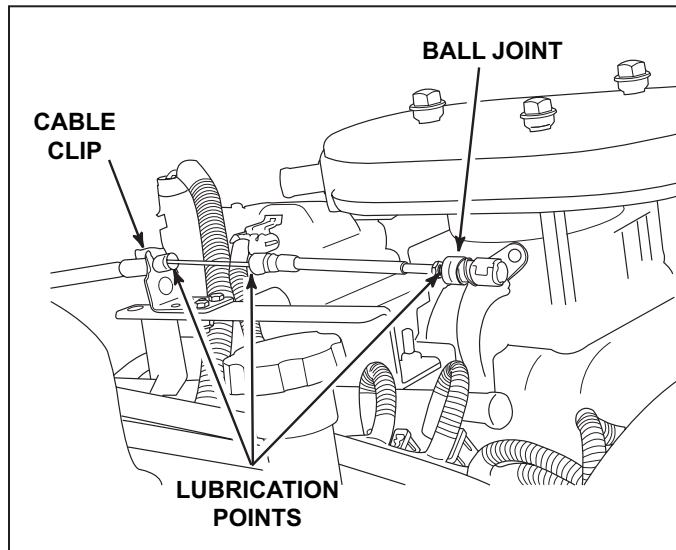

Figure 11-2A Transmission Dipstick and Location

## LUBRICATION

### Throttle Cable

Lubricate pivot points and exposed cable (Figure 11-3) with SAE 30W-30 engine oil.



*Figure 11-3* Typical Throttle Cable

### Shift Cable

Lubricate pivot points and exposed cable (Figure 11-4) with SAE 30W-30 engine oil.

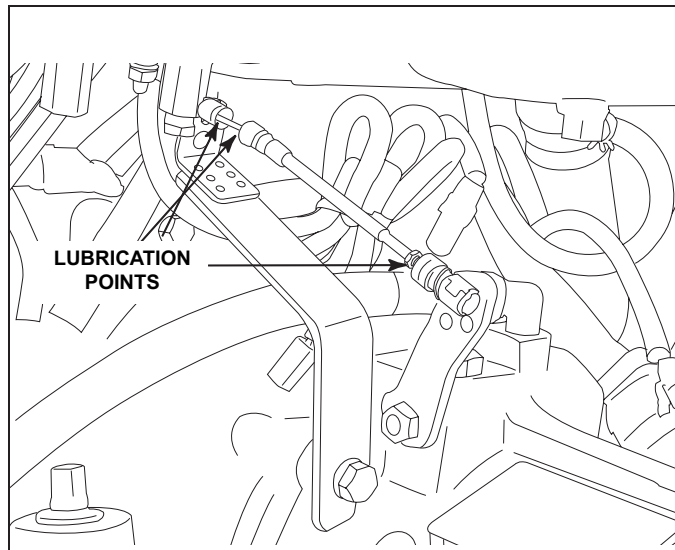

*Figure 11-4* Typical Shift Cable

# ENGINE MAINTENANCE - 11

## ELECTRICAL SYSTEM CIRCUIT BREAKER

### Main Circuit Breaker

PCM engines are equipped with a circuit breaker which provides electrical overload protection for both engine and instrumentation wiring and components. Should an electrical overload occur, the circuit breaker will open and prevent electrical current flow.

When this circuit breaker opens, the cause for the high current draw must be found and corrected. The circuit breaker can be reset by pushing the "Reset" button IN after waiting a few minutes. If the cause of the overload cannot be found, disconnect all accessories which are connected to the main wire harness.

If resetting is still not possible, check the battery and alternator connections and all other harness connectors on the main harness. Check for loose or disconnected lead wires and shorted circuits.

### ELECTRICAL SYSTEM FUSES

PCM engines utilizes fuses to control the fuel pump, ECM and fuel injectors. The fuse block is mounted to a bracket near the exhaust elbow under a weather-tight cover.

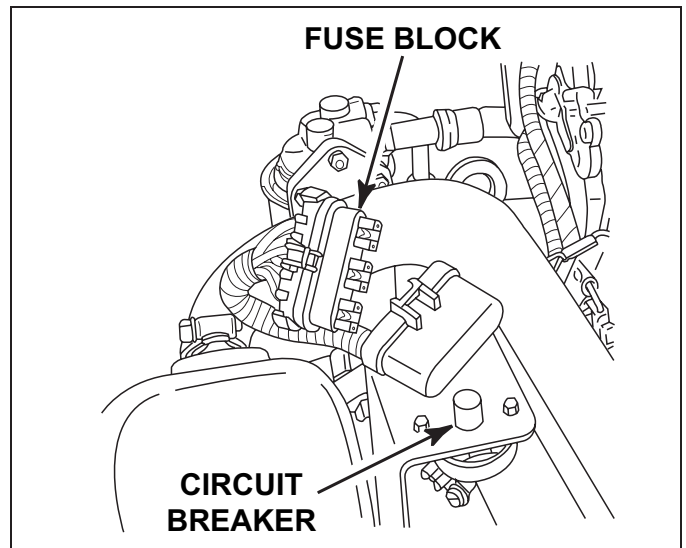

**Figure 11-5** Typical Electrical System Circuit Breaker and Fuses

### IGNITION FUSE

If the engine will not crank when the ignition key is turned to the START position, first check that the shift lever is in neutral position. If the main circuit breaker is not tripped, check for blown ignition fuse. The ignition fuse may be located on the instrument panel, the fuse holder block or as part of the instrument wiring harness. Check the wiring diagrams supplied from the boat manufacturer for the exact location.



### WARNING

Always disconnect the battery cables from the battery, when servicing the electrical system, to prevent personal injury and to prevent damage to the electrical system components.

### ELECTRICAL SYSTEM WIRING AND CONNECTORS

The electrical system wiring and connectors should be checked periodically for loose or dirty connections and damaged wiring. If electrical components or wiring show signs of corrosion, deterioration or damage, consult a PCM Engine dealer to make necessary repairs.



## BATTERY



### WARNING

Battery electrolyte is a corrosive acid and should be handled with care. If electrolyte is spilled or splashed on any part of the body, IMMEDIATELY flush the exposed area with liberal amounts of water and obtain medical aid as soon as possible. Safety glasses and rubber gloves are recommended when handling batteries or filling with electrolyte.



### WARNING

Hydrogen gases that escape from the battery when charging are highly explosive. Do not use jumper cables and a booster battery to start the engine. Do not recharge a weak battery in the boat. Remove the battery from the boat and recharge in a well ventilated area away from fuel vapors, sparks and open flames.

Follow maintenance instructions and warnings as supplied by the battery manufacturer. If this information is not available, follow these guidelines for the proper battery care.

- Do not operate the engine with an open in the battery circuit, as this may cause damage to the alternator. Make sure that all connections are clean and secure.
- When removing the battery cables, always remove negative (-) cable first, and then remove the positive (+) cable. When installing battery cables, install the positive (+) cable first, then install the negative (-) cable.
- Periodically check the battery for signs of corrosion, frayed battery leads or cracked case. Repair or replace as necessary.
- Periodically check the electrolyte level. Add distilled water to bring up to the proper levels.

# ENGINE MAINTENANCE - 11

## FRESH-WATER COOLING SYSTEM SACRIFICIAL ZINC ANODE

Located in the raw water side of the heat exchanger is a zinc anode which is marked by a decal. To check, remove the plug and visually check the condition of the zinc rod. The length of the zinc rod when new is approximately 1.5 inches. If more than one half of the zinc is gone, replace with a new zinc anode.

Different geographic locations and water make-up can result in either high or low sacrificial requirements. A high rate of zinc anode consumption should also alert the owner to a possibility of an improperly wired boat accessory, which would require complete checking by qualified service personnel.

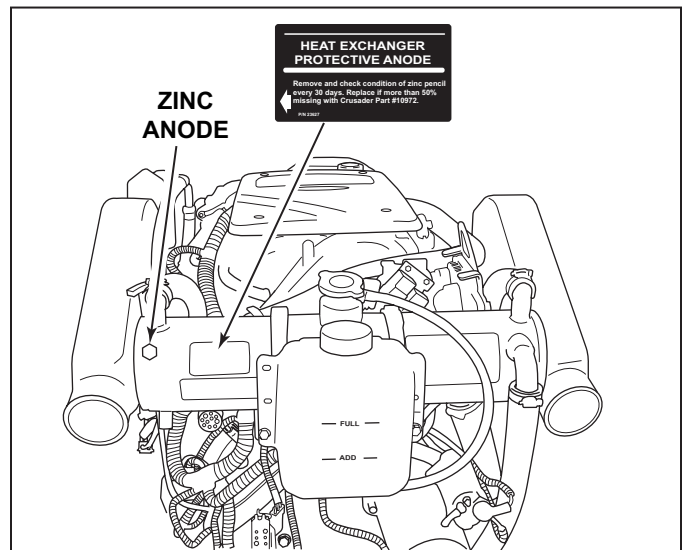

**Figure 11-6** Zinc Anode Location F.W.C. Heat Exchanger (8.1L)

## CHECKING COOLANT LEVEL



### WARNING

Do not remove cooling system filler cap when the engine is hot. Allow the engine to cool and then remove the pressure cap slowly, allowing the pressure to vent. Hot coolant, under pressure, may discharge violently and cause severe burns.

### Coolant Recovery Reservoir

The “see-through” plastic reservoir is connected to the heat exchanger by a small hose. The recovery bottle collects coolant that expands with rising temperature, and would otherwise overflow from the system. Coolant level should be at or slightly above the “ADD” mark on the bottle when the system is cold. Coolant should be added ONLY to the reservoir when the system cools. Add specified coolant as required.

### Coolant Filler Neck

Periodically, on a cool engine, remove the pressure cap from the filler neck to ensure the coolant recovery system is functioning properly. Coolant must be at the top of the filler neck. If coolant is low, check the gasket in the cap for damage. Replace if necessary. Inspect the coolant recovery system for leaks.

### Degas Bottle

The “see-through” degas bottle is connected to the heat exchanger by a small hose. The degas bottle collects coolant that expands with rising temperature, and would otherwise overflow from the system. Coolant level should be at or slightly above the “ADD” mark on the bottle when the system is cold. Coolant should be added ONLY to the bottle when the system cools. Add specified coolant as required.

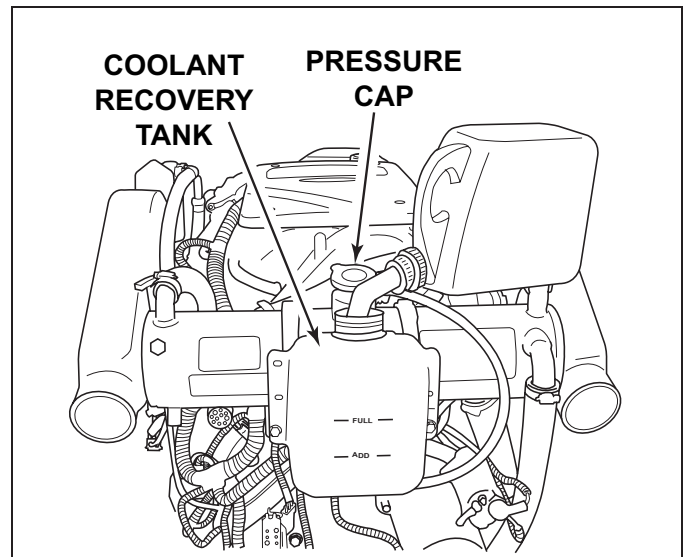

**Figure 11-7** Checking Coolant Level (8.1L)

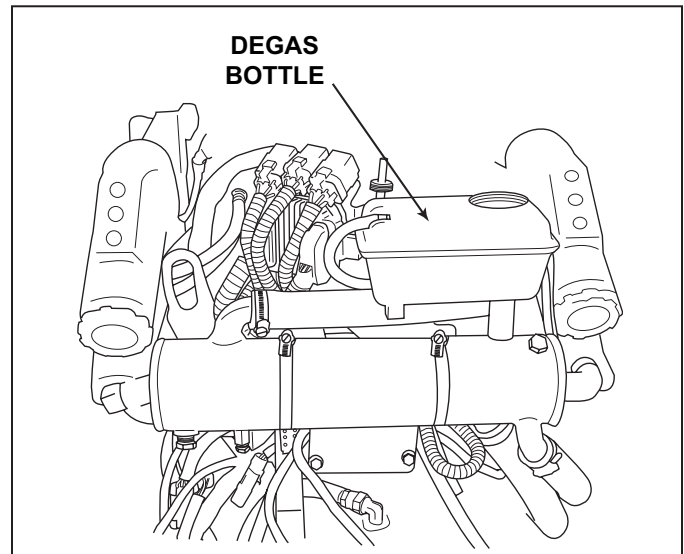

**Figure 11-8** Checking Coolant Level (6.0L)

# ENGINE MAINTENANCE - 11

## FLUSHING COOLING SYSTEM - SEA-WATER SECTION

To prevent silt and/or salt build-up in the cooling system (fresh or raw-water cooled), flush the sea-water section of the cooling system with fresh water at specified intervals. Close seacock (if applicable) before removing inlet hose.



### CAUTION

Do not operate the engine without sufficient amount of water being supplied to the sea-water pump. The sea-water pump impeller may be damaged and subsequent overheating damage may result.



### CAUTION

Do not run the engine above 1500 RPM when flushing. Suction created by the sea-water pump may collapse the flushing hose, causing the engine to overheat. Watch the temperature gauge while flushing to ensure the engine does not overheat.

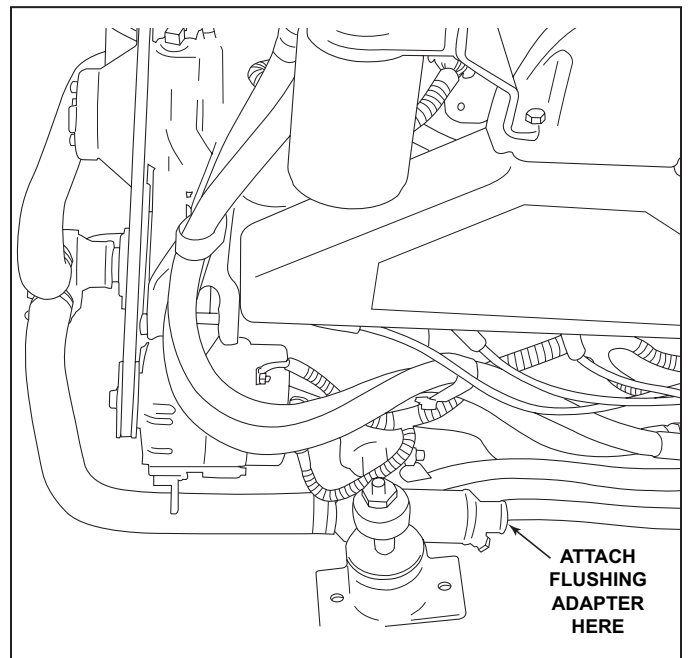

**Figure 11-9** Typical Sea-Water Inlet

## TESTING COOLANT FOR ALKALINITY

It is recommended that the coolant in the fresh-water section be tested each year for alkalinity. Coolant that is not alkaline has lost the effectiveness of its rust inhibitors, which can lead to internal corrosion and cooling system problems. It is recommended to replace the standard ethylene glycol coolant in the system every two years to prevent a build-up of harmful chemicals within the fresh-water system.



### WARNING

Do not remove cooling system filler cap when the engine is hot. Allow the engine to cool and then remove the pressure cap slowly, allowing the pressure to vent. Hot coolant, under pressure, may discharge violently and cause severe burns.

1. Obtain red litmus paper from a local supplier (drugstore, laboratory, etc.).
2. Remove the pressure cap from the coolant filler neck and insert one end of the litmus paper into the coolant.
3. If red litmus paper turns blue, coolant is alkaline and does not need to be replaced. If the litmus paper remains red, the coolant is not alkaline and must be replaced.



### WARNING

Do not remove cooling system filler cap when the engine is hot. Allow the engine to cool and then remove the pressure cap slowly, allowing the pressure to vent. Hot coolant, under pressure, may discharge violently and cause severe burns.

## DRAINING FRESH-WATER COOLING SYSTEM

**NOTICE:** To protect the environment, dispose of coolant properly. Check your local restrictions for proper disposal instructions of removed coolant.

**NOTICE:** Refer to cooling system water flow diagrams for drain locations.

1. Remove the following drain plugs to drain coolant from the fresh-water cooling system:
  - Drain plug on heat exchanger
  - Remove the large hose from the engine block water circulating pump, or drain plug on circulation pump
  - Drain plugs on the cylinder block (one on each side)
2. Remove the following drain plugs to raw water from the fresh-water cooling system:
  - Drain plug on oil cooler
  - Drain plug on heat exchanger
  - Drain plug on the bottom of each exhaust manifold
3. After system has drained completely, coat all the drain plugs with PerfectSeal (or equivalent) and reinstall in the proper locations. Reinstall the hose(s) on the water circulating pump and tighten the clamps securely.

# ENGINE MAINTENANCE - 11

## FILLING FRESH-WATER COOLING SYSTEM

A new extended life engine coolant known as DEX-COOL™ is used in your engine(s). It is imperative to note the following about DEX-COOL™ engine coolant:

- IT IS PINK IN COLOR TO DISTINGUISH IT FROM CONVENTIONAL COOLANT.
- THE SERVICE CHANGE INTERVAL ON ENGINES BUILT WITH DEX-COOL™ IS 5 YEARS.
- TO MAINTAIN FULL CORROSION PROTECTION DURABILITY, DEX-COOL™ MUST NOT BE MIXED WITH CONVENTIONAL (CONTAINING SILICATE) ENGINE COOLANTS.
- DEX-COOL™ IS AN ETHYLENE GLYCOL BASED PRODUCT, THEREFORE, BOIL AND FREEZE PROTECTION ARE MEASURED IN THE SAME FASHION AS CONVENTIONAL COOLANTS.

TO FULLY REALIZE ITS MANY ADVANTAGES, DEX-COOL™ MUST NEVER BE MIXED WITH CONVENTIONAL COOLANTS.

DEX-COOL™ can become contaminated by inadvertently topping-off with conventional coolant, adding conventional coolant to the system or even if fill/drain containers are shared between coolants. If contamination occurs, the cooling system must be immediately drained and flushed, and refilled with DEX-COOL™. No short-term damage will occur, however, the service interval will be reduced from 5 years to 2 years.

The fresh-water cooling side of the cooling system must be filled with a 50/50 mixture of DEX-COOL™ (or equivalent, which meets GM6277M) extended life antifreeze and water solution.

**IMPORTANT:** More than 50% antifreeze solution can contribute to an overheating condition.

**IMPORTANT:** If the engine is being placed in winter storage, the fresh-water cooling section must be filled with a correct type of coolant and water solution, properly mixed, to protect the engine to the lowest temperature to which it will be exposed.

1. Make sure that all drain plugs are properly installed.
2. Remove the pressure cap. Fill the system with antifreeze solution until the system is filled. See ENGINE FLUID CAPACITIES for system capacities.

3. Start the engine and operate at idle speed (800-1000 RPM) to purge any air from the system. When the system is full, install the pressure cap.

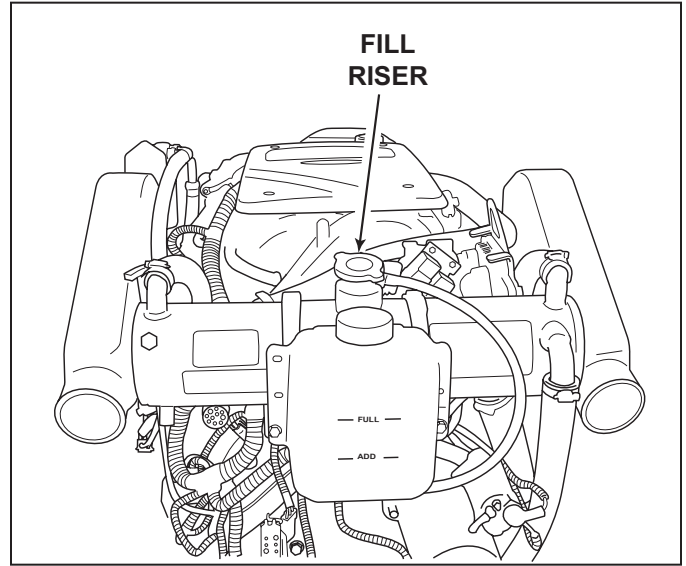

**Figure 11-10** F.W.C. Fill Riser Location (8.1L)

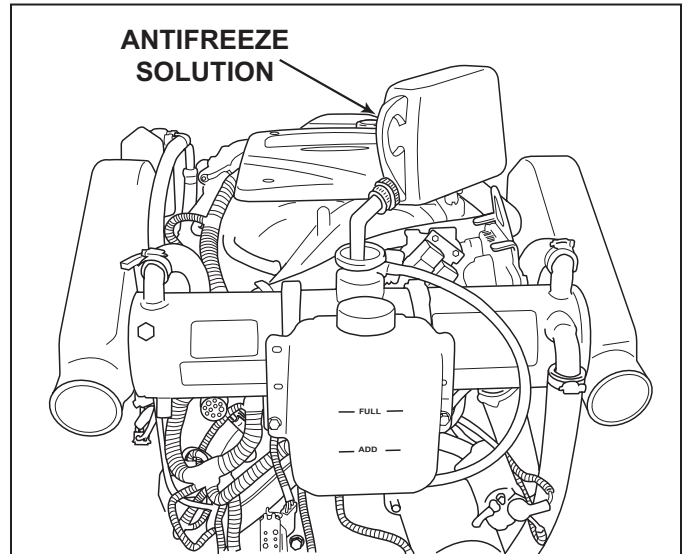

**Figure 11-11** Filling F.W.C. System (8.1L)

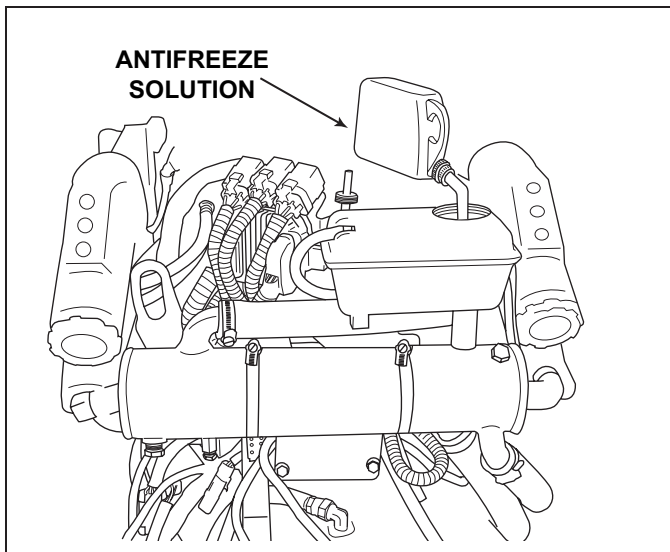
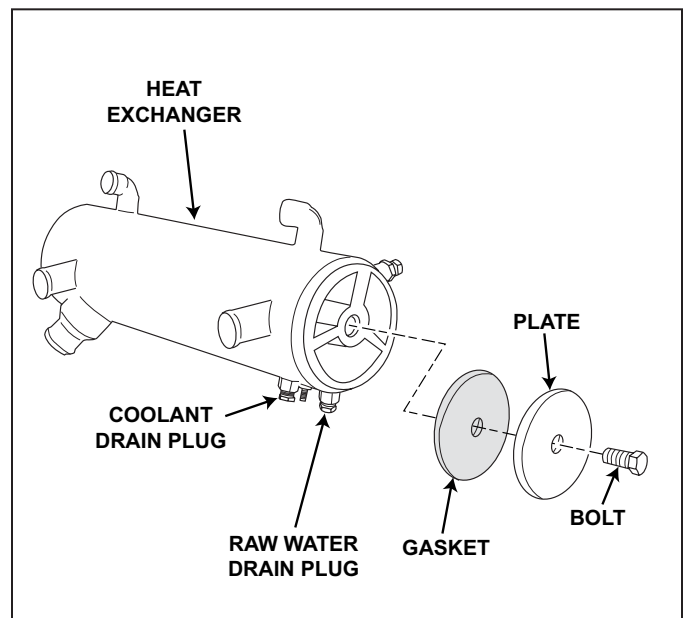

**Figure 11-12** Filling F.W.C. System (6.0L)

## CLEANING SEA-WATER SECTION OF HEAT EXCHANGER - FRESH-WATER COOLED MODELS ONLY

The sea-water section of the heat exchanger should be cleaned whenever there is a noticeable decrease in cooling efficiency. You may use the following procedure for cleaning, or, if the build-up of scale and mineral deposits is heavy, it is recommended that the heat exchanger be removed and taken to a repair facility to be boiled out (such as a radiator repair facility).

1. Remove the bolts securing the heat exchanger end plates. Remove the end plates and gaskets.
2. Clean the water passages in the heat exchanger by inserting a suitable-size wire brush into each passage. Use compressed air to blow out loose particles.
3. Clean the gasket surfaces on the end plates and the heat exchanger. Apply PerfectSeal to both sides of the new gaskets. Install the end plates and the new gaskets onto the heat exchanger. Install the bolts and tighten securely.
4. Start the engine and inspect for leaks.



**Figure 11-13** Heat Exchanger and End Plate Removal (Typical)

# ENGINE MAINTENANCE - 11

## FUEL SYSTEM DESCRIPTION



### WARNING

Extreme caution must be exercised when servicing the fuel system and/or replacing fuel filter. Gasoline is extremely flammable and highly explosive under certain conditions. Be sure the ignition key is off and do not smoke or allow open flame in the area while servicing. Wipe up any spilled fuel immediately.



### WARNING

Extreme caution must be exercised when servicing the fuel system. The fuel system operates under high pressure. Use caution when removing or replacing components, as residual pressure may be present.



### WARNING

Make sure that there are no fuel leaks before closing the engine hatch.



### WARNING

Visually inspect unit for fuel leaks before operating the engine. If fuel leaks are present, DO NOT operate the engine, contact your service center immediately.

## Fuel Control Cell (FCC) Fuel System

The Fuel Control Cell (FCC) eliminates vapor lock and air ingestion caused by fuel tank slosh, and provides the necessary filtration and water separation.

The FCC system incorporates two (2) fuel pumps to provide an uninterrupted flow of fuel to your PCM marine engine. Fuel is fed into the FCC bowl by a low-pressure, high-volume electric fuel pump. This pump flows fuel at a volume much greater than the fuel flow rate required of the high-pressure pump and engine demands. The high-pressure pump, mounted inside the FCC bowl, provides the necessary fuel pressure and volume to maintain proper engine performance. The FCC constantly has an ample supply of fuel to meet the idle, cruise and acceleration fuel requirements of the engine.

The fuel pressure regulator, located on the fuel rail, controls the fuel pressure, and maintains a constant pressure across the fuel delivery system. Excess fuel, not used by the engine, returns to the FCC bowl. The 6.0L fuel pressure regulator is located inside the FCC bowl.

The fuel delivered to the engine by the FCC is filtered by a filter and water separator element, which surrounds the high pressure pump inside the FCC bowl.

As indicated above, fuel enters the FCC bowl from two (2) locations, the low-pressure pump (initial input) and the fuel pressure regulator (unused, recirculating fuel). Fuel exits the FCC bowl at two (2) locations, the high-pressure output to the fuel injection system and all excess fuel in the FCC bowl is routed back to the tank via the return line.



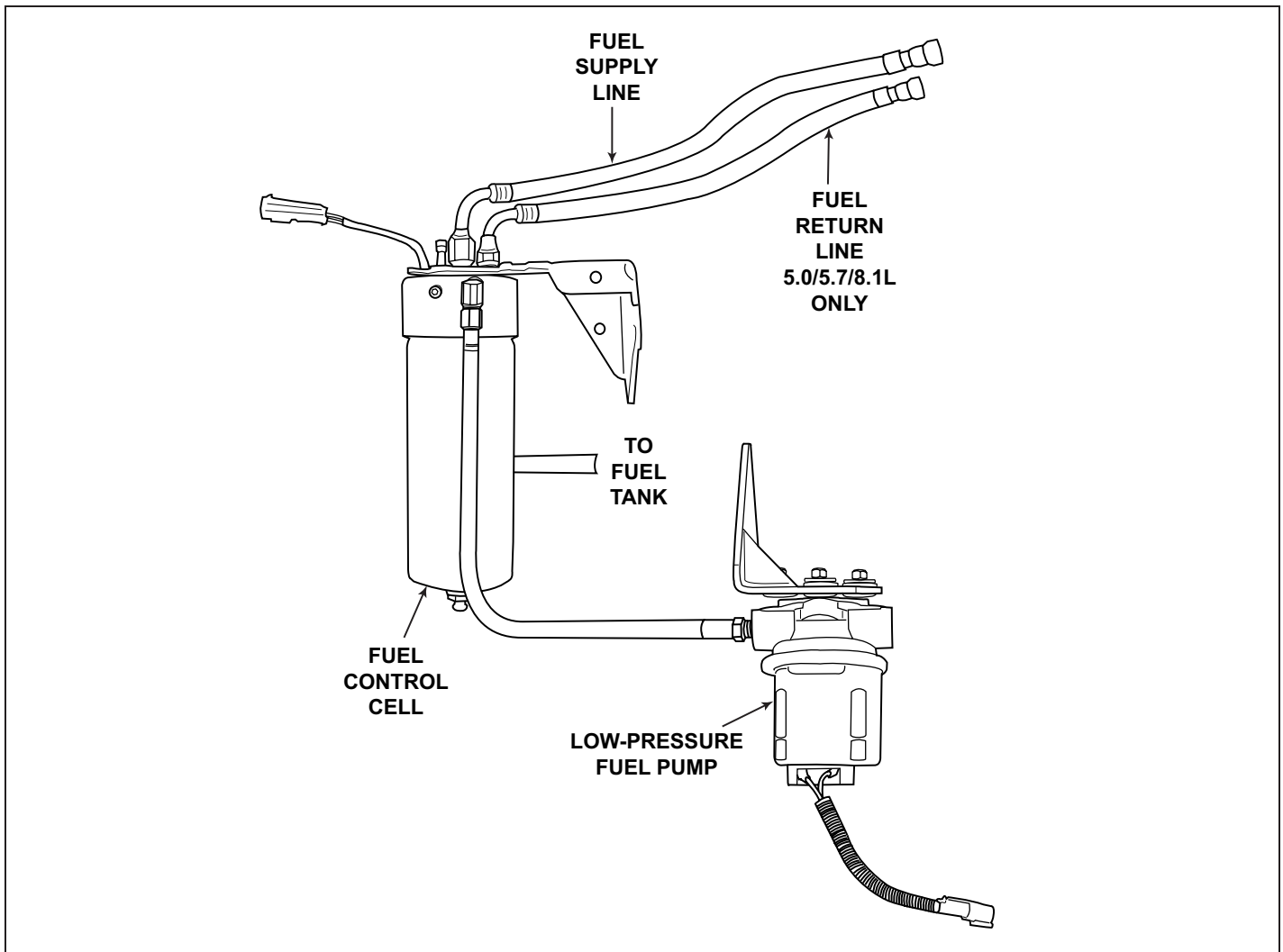

**Figure 11-14** Fuel Control Cell (FCC) Fuel System (Typical)

### Servicing the FCC

The frequency of draining the water or replacing the filter element is determined by the contamination level of the fuel. Replace the filter element at least once a year, or when a loss of power is noticed (whichever occurs first).



### WARNING

Improper use, installation or servicing may cause an explosion or fire resulting in bodily injury, or death. This unit should only be serviced by a qualified technician. Read and follow all instructions before proceeding. Run the engine and check for fuel leaks after installation, element replacement or draining the bowl. DO NOT remove the FCC bowl unless servicing the filter element, otherwise contamination or bowl O-ring swelling may result.

# ENGINE MAINTENANCE - 11

## Primary Fuel Filter



### WARNING

Extreme caution must be exercised when servicing the fuel system. The fuel system operates under high pressure. Use caution when removing or replacing components, as residual pressure may be present.

### Draining the FCC Bowl, ENGINE OFF

1. Disconnect the two-wire electrical connector.
2. Hold the 3/4" jam nut, located at the bottom of the FCC bowl, with a wrench. Remove the 7/16" plug, and drain the bowl contents into an approved container.

**CAUTION: Both fuel and water will drain from the FCC bowl.**

3. Apply pipe sealant, suitable for use with gasoline, to the threads of the 7/16" plug.
4. Tighten the 7/16" plug while holding the 3/4" jam nut with a wrench.
5. Reconnect the two-wire electrical connector.
6. Cycle the ignition key several times to run the electric fuel pumps and fill the FCC bowl with fuel. Inspect the drain plug area for leaks. Correct any leaks prior to operating the engine.
7. Start the engine and inspect for fuel leaks. Correct any leaks prior to operating the engine any further.

### Filter Element Replacement, ENGINE OFF

1. Disconnect the two-wire electrical connector.
2. Hold the 3/4" jam nut, located at the bottom of the FCC bowl, with a wrench. Remove the 7/16" plug, and drain the bowl contents into an approved container.

**CAUTION: Both fuel and water will drain from the FCC bowl.**

3. Using a strap-type oil filter wrench, remove the FCC bowl by turning it counterclockwise as view from the bottom.
4. Slide the bowl downward over the suspended filter element. It may be necessary to pull the unit to one side in order to remove the FCC bowl.
5. Remove the fuel filter element from the suspended pump by gripping the fuel pump with one hand, and pulling the filter element downward with the other hand.
6. Push on new filter element (part number RP080026) over the electric fuel pump.

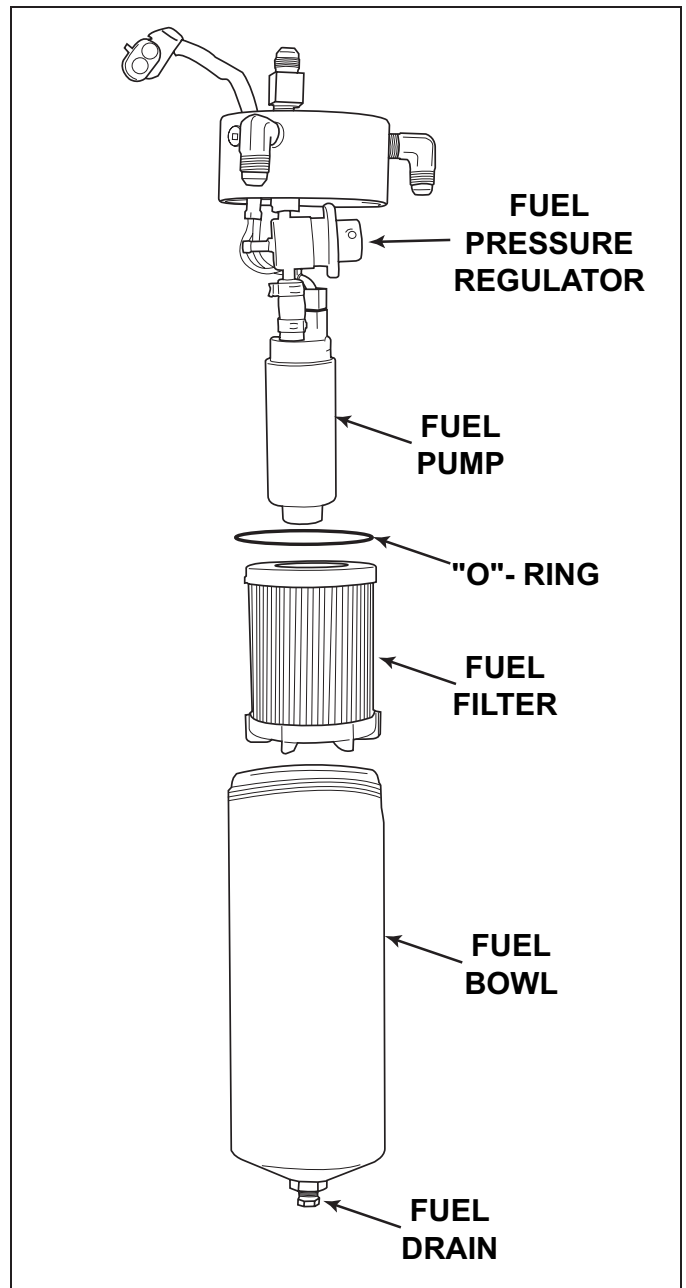

**Figure 11-15** Fuel Control Cell (FCC) (6.0L)

7. Using a pick made of soft material, such as a toothpick, remove the old O-ring from the inside of the FCC bowl mounting head.

**CAUTION: The mounting head O-ring groove may be damaged by using sharp steel tools to remove this O-ring.**

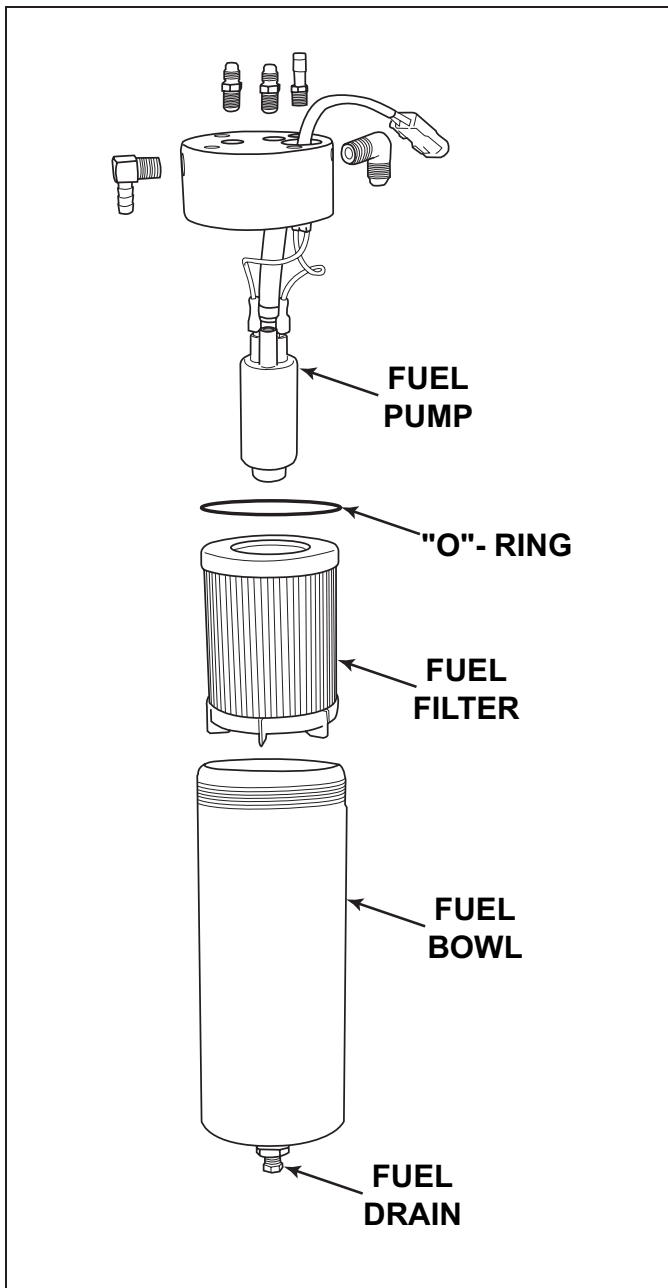

**Figure 11-15A** Fuel Control Cell (FCC) (Typical)

8. Lubricate the new O-ring with a light grease and install the new O-ring into the FCC bowl mounting head.
9. Apply pipe sealant, suitable for use with gasoline, to the threads of the 7/16" plug.
10. Install and tighten the 7/16" plug while holding the 3/4" jam nut with a wrench.
11. Grease taper and the threads on the FCC bowl and, by hand, thread the FCC bowl into the FCC mounting head. Tighten the bowl firmly back into the mounting head with an oil filter wrench.
12. Reconnect the two-wire electrical connector.
13. Cycle the ignition key several times to run the electric fuel pumps and fill the FCC bowl with fuel. Inspect the drain plug area for leaks. Correct any leaks prior to operating the engine.
14. Start the engine and inspect for fuel leaks. Correct any leaks prior to operating the engine any further.

**DO NOT ATTEMPT TO SERVICE ANY OTHER PARTS ON THIS UNIT.**

# ENGINE MAINTENANCE - 11



## WARNING

Make sure there are no fuel leaks before closing the engine hatch.

### Priming Fuel System

To prime the fuel system, cycle the ignition key 3 times using the following procedures:

1. Turn ignition key to ON position for 5 seconds.
2. Turn ignition key OFF.
3. Pause for 10 seconds.
4. Repeat steps 1-3 three times.

Crank the engine until it starts or 30 seconds elapse. If the engine does not start, repeat the priming procedures.

### FLAME ARRESTOR

At specified intervals, the flame arrestor should be checked for blockage caused by dirt or other foreign material.

Loosen the clamp securing the flame arrestor to the air intake tube or throttle body. Remove the flame arrestor. Clean the flame arrestor with solvent and dry with compressed air. Reinstall the flame arrestor and tighten the clamp(s) securely.

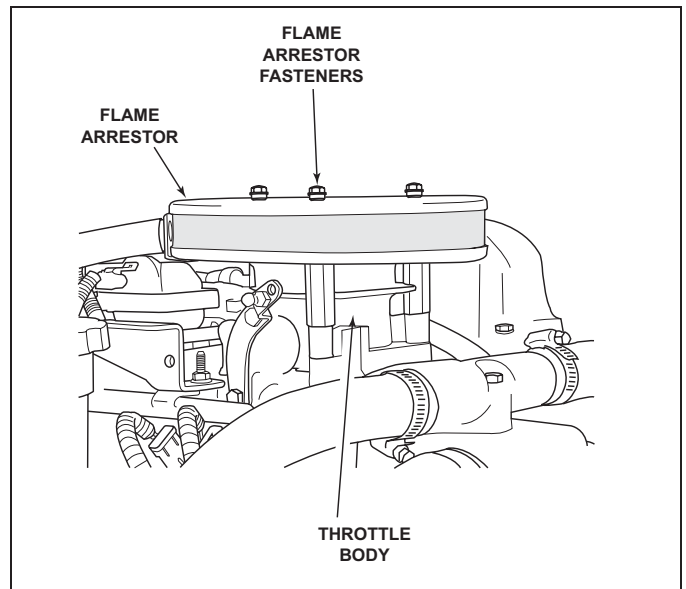

Figure 11-16 Flame Arrestor - 5.7L (Typical)

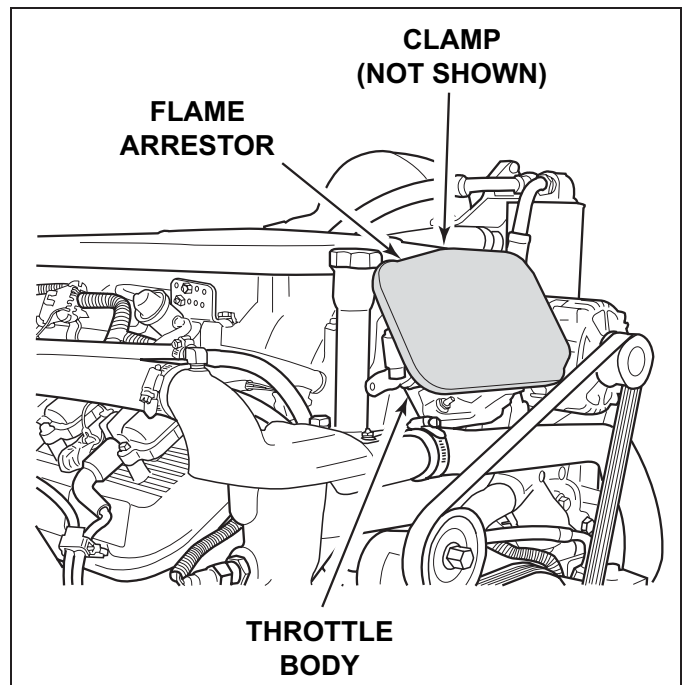

Figure 11-17 Flame Arrestor - 8.1L (Typical)

## DRIVE BELT INSPECTION

Inspect the drive belt for excessive wear, shredding or missing sections.

Inspect the drive belt for contamination from excessive dirt, oil, coolant or other substances that may effect the drive belt operation.

If a problem is found, replace the belt after inspecting the following items:

- All pulleys and tensioners for signs of misalignment
- All pulleys and tensioners for signs of rust or other damage
- Bent pulleys or tight bearings in the engine water circulation pump, sea-water pump and alternator

## 8.1L ACCESSORY DRIVE BELT

The PCM 8.1L engine uses a single serpentine belt to drive the engine water circulation pump and the alternator. The sea-water pump is mounted onto the crankshaft pulley and is driven directly by the crankshaft.



### CAUTION

The replacement of the drive belt requires the removal of the inlet hose from the sea-water pump. With the hose removed, it is possible for water to enter the bilge of the boat, and possibly sink it. ALWAYS plug the inlet hose securely to prevent this possibility from occurring.

## DRIVE BELT REPLACEMENT (8.1L)

1. Remove the inlet and outlet hoses from the sea-water pump, being careful not to allow the hose clamps to fall into the bilge.
2. Remove the bolt and washers that attach the sea-water pump to the bracket, being careful not to allow the bolt and washers to fall into the bilge.
3. Loosen the bolts that attach the bracket to the engine block until a gap, large enough to pass the belt through, is created.
4. Note the routing of the belt before removing.

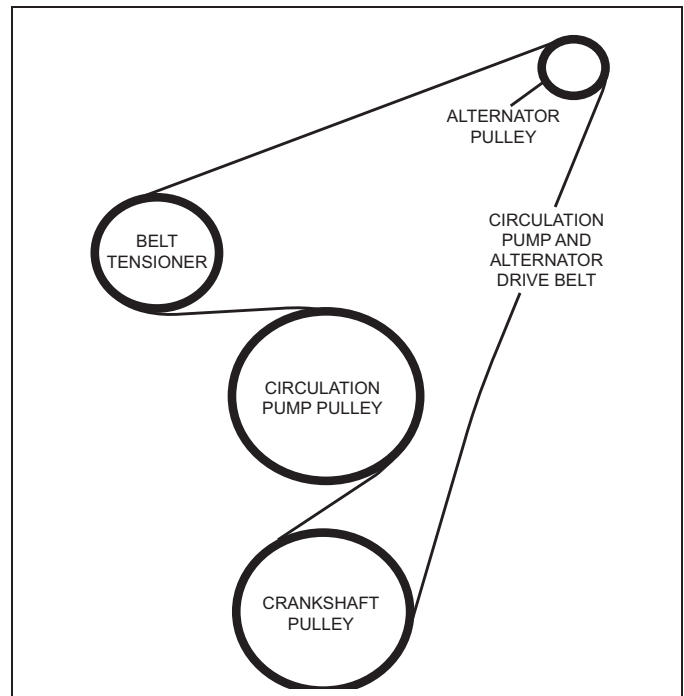

**Figure 11-18** 8.1L Accessory Drive Belt Configuration

# ENGINE MAINTENANCE - 11

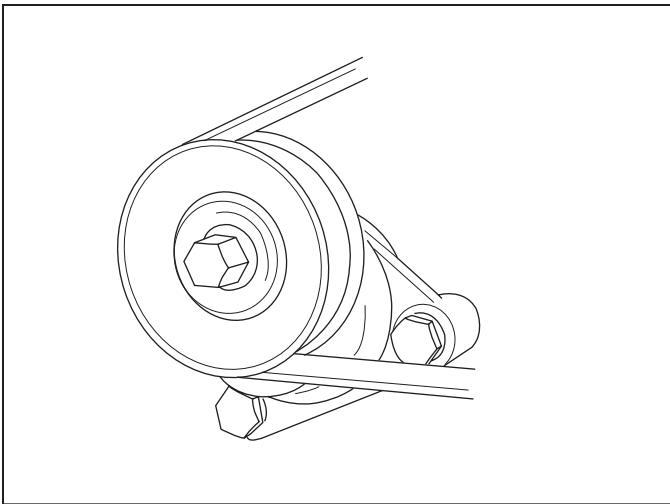

**Figure 11-19** Belt Tensioner (8.1L)

5. Using a 15 mm box wrench or socket, turn the belt tensioner to relieve the tension on the belt. Slide the belt off of the pulleys and through the gap between the sea-water pump and the bracket. **Release the tensioner slowly to prevent the tensioner from snapping against its stop, and possibly causing damage to the tensioner.**
6. Slide the new belt through the gap between the sea-water pump and the bracket. Slide the belt onto the pulleys using the same routing as noted prior to removal.
7. Compress the belt tensioner, and slide the belt over the tensioner pulley. Release the tension slowly to tension the belt.
8. Position the bracket onto the sea-water pump anchor boss, and install the flat washer, lock washer and bolt to the pump.
9. Tighten the bracket-to-engine block attaching bolts to 18 lb. ft.
10. Tighten the bolt that secures the sea-water pump to the bracket to 12 lb. ft.
11. Install the inlet and outlet hoses to the sea-water pump. Position the hoses and clamps so that the clamps are clamping on the pump side of the fitting bead. Tighten the clamps securely.

## 6.0L ACCESSORY DRIVE BELT

The PCM 6.0L engine uses a single serpentine belt to drive the engine water circulation pump, sea-water pump and the alternator.

### DRIVE BELT REPLACEMENT (6.0L)

1. Note the routing of the belt before removing.
2. Using a 15 mm box wrench or socket, turn the belt tensioner to relieve the tension on the belt. Slide the belt off of the pulleys. **Release the tensioner slowly to prevent the tensioner from snapping against its stop, and possibly causing damage to the tensioner.**

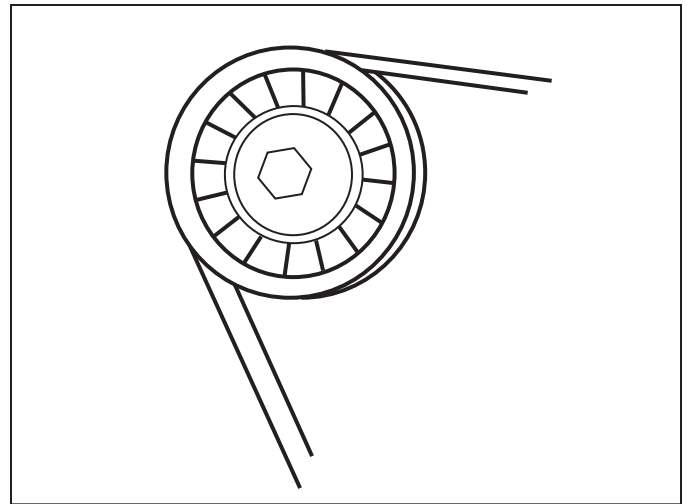

Figure 11-21 Belt Tensioner (6.0L)

3. Slide the new belt onto the pulleys using the same routing as noted prior to removal.
4. Compress the belt tensioner, and slide the belt over the tensioner pulley. Release the tension slowly to tension the belt.

### SERVICING RAW WATER PUMP IMPELLER (6.0L)

The raw water pump impeller should be serviced every 50 hours, or once a year, whichever occurs first. See Maintenance Schedule.

Locations "A" (Figure 11-20) are access holes in order to loosen the raw water pump attaching bolts. The bolts are secured in the pump by O-rings, and will not fall out during removal.

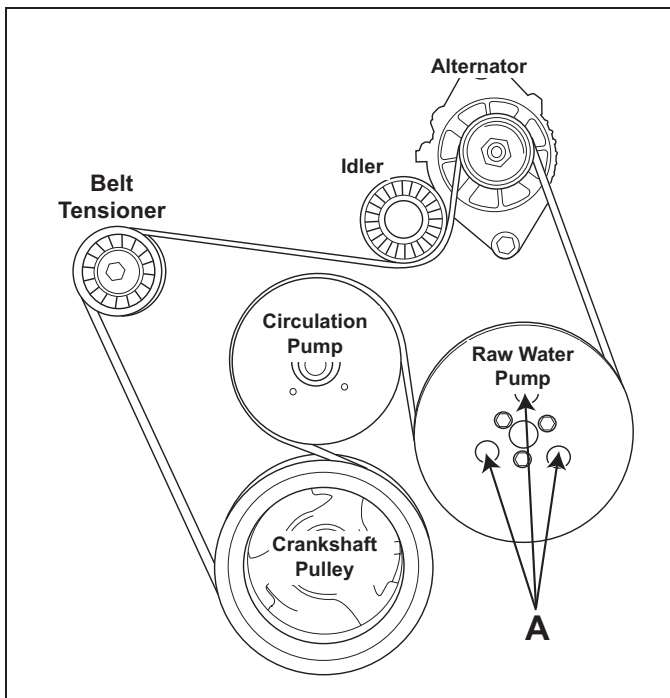

Figure 11-20 6.0L Accessory Drive Belt Configuration

# ENGINE MAINTENANCE - 11



## WARNING

Engine must be shut OFF and the ignition key removed before inspecting the drive belt(s). The drive belt(s) should be checked periodically for condition and tension. If the belt(s) shows signs of cracking, glazing or deterioration, replace with new belt(s).

### 5.0/5.7L ACCESSORY DRIVE BELT

The PCM 6.0L engine uses a single serpentine belt to drive the engine water circulation pump, sea-water pump and the alternator.

### DRIVE BELT REPLACEMENT (5.0/5.7L)

1. Note the routing of the belt before removing.
2. Using a 15 mm box wrench or socket, turn the belt tensioner to relieve the tension on the belt. Slide the belt off of the pulleys. **Release the tensioner slowly to prevent the tensioner from snapping against its stop, and possibly causing damage to the tensioner.**

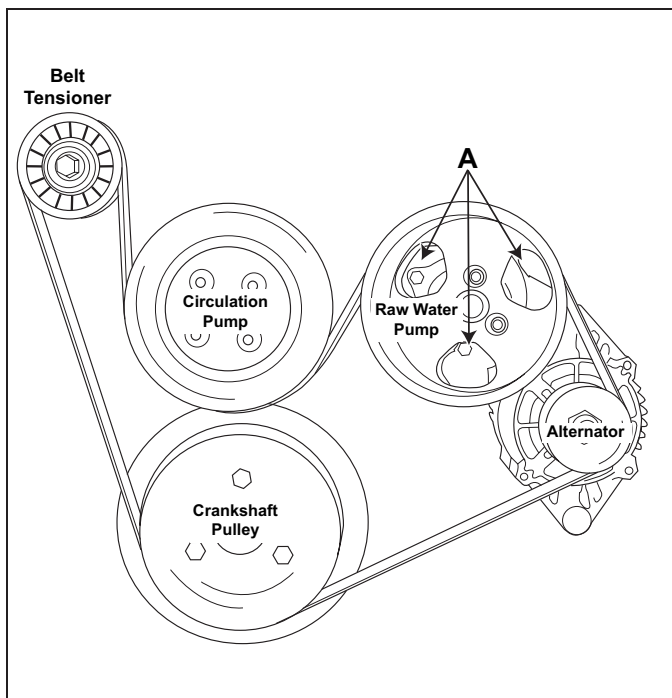

Figure 11-22 5.0/5.7L Accessory Drive Belt Configuration

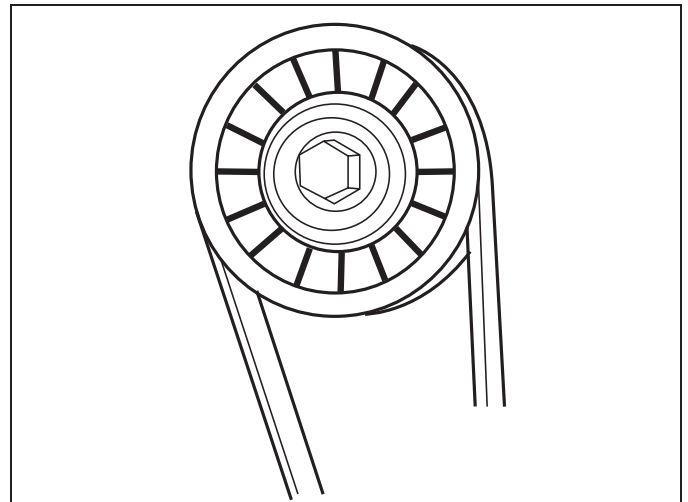

Figure 11-23 Belt Tensioner (5.0/5.7L)

3. Slide the new belt onto the pulleys using the same routing as noted prior to removal.
4. Compress the belt tensioner, and slide the belt over the tensioner pulley. Release the tension slowly to tension the belt.

### SERVICING RAW WATER PUMP IMPELLER (5.0/5.7L)

The raw water pump impeller should be serviced every 50 hours, or once a year, whichever occurs first. See Maintenance Schedule.

Locations "A" (Figure 11-22) are access holes in order to loosen the raw water pump attaching bolts. The bolts are secured in the pump by O-rings, and will not fall out during removal.



## CHANGING OILS



### WARNING

**IMPORTANT:** The Federal Water Pollution Control Act prohibits the discharge of oil or oily waste into or upon the navigable waters and continuous zone of the United States, if such discharge causes a film or sheen upon, or discoloration of the surface of the water, or causes sludge or emulsion beneath the surface of the water. Violators are subject to a penalty of \$5,000.00.

Refer to the MAINTENANCE SCHEDULE for oil change intervals. The engine and transmission oils should be changed prior to placing the boat into storage.

The transmission oil change should be performed by an authorized dealer, at specified intervals.

**IMPORTANT:** Change the engine oil when the engine is warm from operation. Warm oil flows more freely, and allows more foreign material and impurities to be removed.

The engine oil filter is remote mounted. The engine block location, where the filter is normally mounted, is covered with an oil filter bypass adapter. **DO NOT** remove this adapter when changing the oil.

1. With the engine at normal operating temperature, remove the dipstick and install a crankcase oil pump onto the dipstick tube (Figure 11-24). Insert the discharge hose into a suitable container. Pump the oil from the engine until the crankcase is empty. Remove the oil pump from the dipstick tube.
2. Remove the oil filter by turning it counterclockwise, using an oil filter wrench if necessary. Discard the old filter and sealing ring.

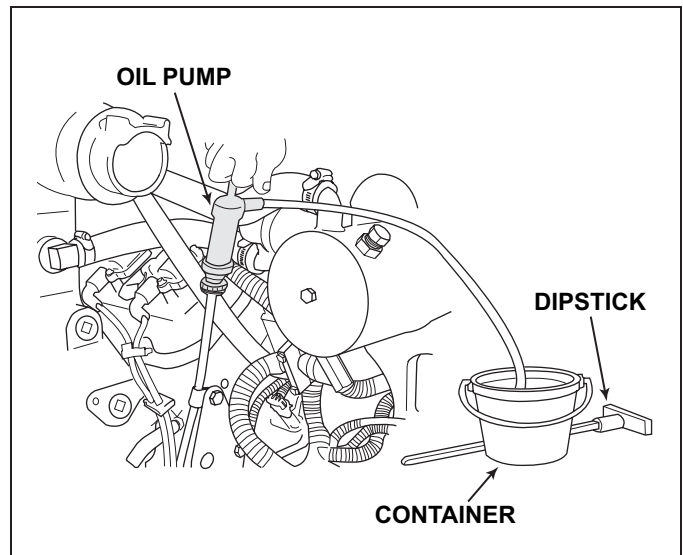

**Figure 11-24** Engine Oil Removal

3. Coat the sealing ring, on the new filter, with a light coating of clean engine oil. Install the oil filter securely by hand. **DO NOT** overtighten.
4. Fill the engine with the recommended oil, see OIL REQUIREMENTS, through the oil fill location on the valve cover (Figure 11-25).

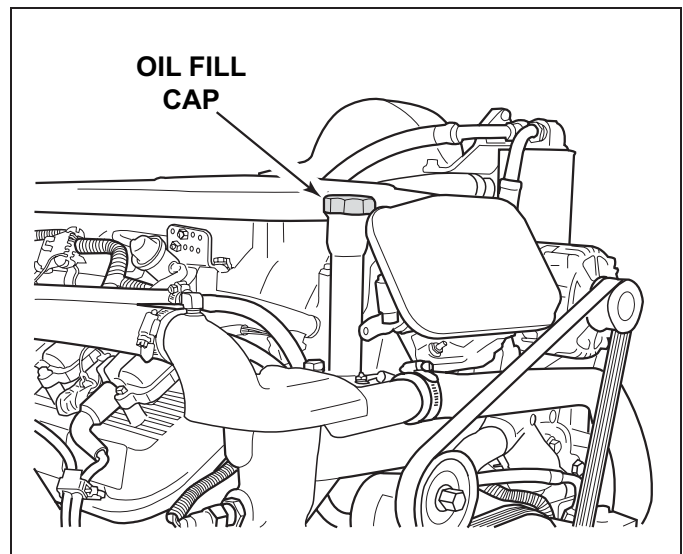

**Figure 11-25** Engine Oil Fill (8.1L)

5. Start the engine and operate for 5 minutes to circulate the oil throughout the engine. Check entire system for leaks, especially around the oil filter.
6. Stop the engine and wait 5 minutes to allow the oil to completely drain down. Check the oil level and add oil, if needed, to bring the engine oil to the proper level.

# ENGINE MAINTENANCE - 11

## ENGINE ALIGNMENT



### CAUTION

Engine must be properly aligned, or vibration, noise and damage to the transmission output shaft oil seal and bearings may result.

**IMPORTANT:** Engine alignment **MUST BE RECHECKED** with the boat in the water, fuel tanks full and with a normal load on the boat. Engine must be aligned so that the transmission and the propeller shaft coupling center lines are aligned, and coupling faces are parallel within 0.003 in. (0.07 mm). This applies to installations with solid couplings, as well as flexible couplings.

1. Check the mating surfaces on the transmission and the propeller shaft couplings. Make sure they are clean and flat (Figure 11-26).

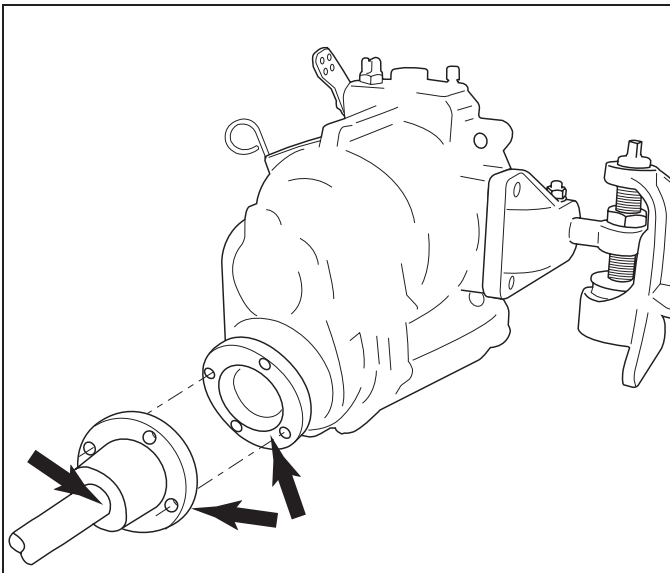

**Figure 11-26** Shaft Mating Surface Check

2. Center the propeller shaft in the shaft log as follows: (Figure 11-27)
  - Push down and then lift the propeller shaft as far as it will move, then place the shaft in the middle of the movement.
  - Move the shaft to the port and then to the starboard as far as the shaft will move, then place the shaft in the middle of the movement.
  - With the propeller shaft in the middle of the shaft log, align the engine to the shaft.

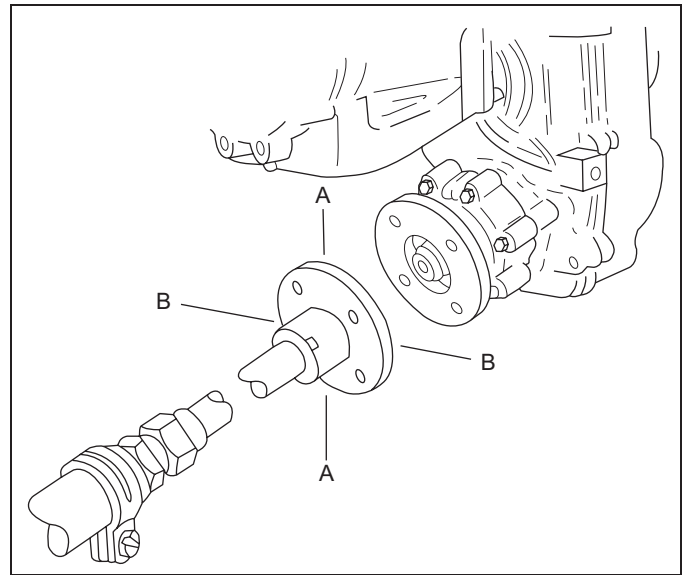

**Figure 11-27** Centering Prop Shaft

3. Check that the coupling center lines align by butting the propeller shaft coupling against the transmission coupling (Figure 11-28). The shoulder on the propeller shaft coupling face should engage the recess on the transmission coupling face, with no resistance.

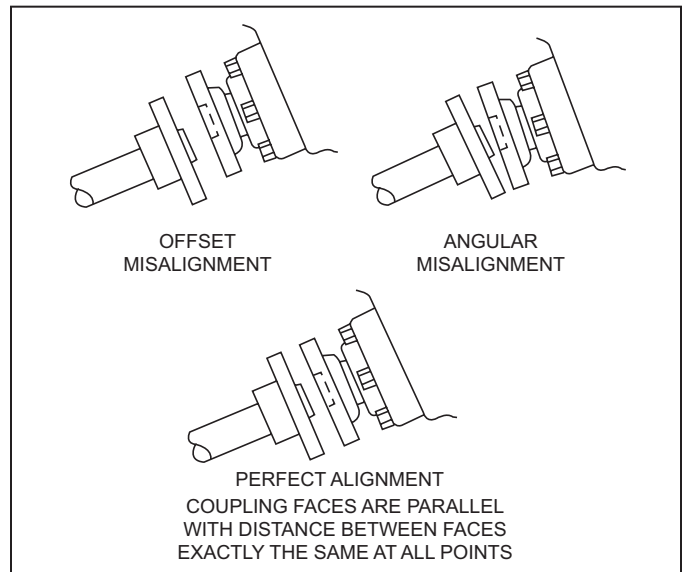

**Figure 11-28** Shaft Mating Surface Check

**IMPORTANT:** Offset misalignment conditions must be corrected prior to checking for angular misalignment.

**NOTICE:** Some propeller shaft couplings may not have a shoulder on the mating surface. On these installations, use a straight edge to check the centerline alignment (Figure 11-29).

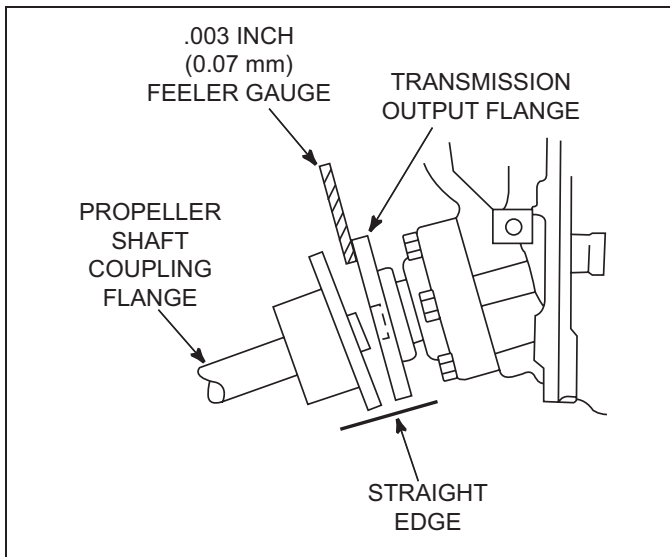
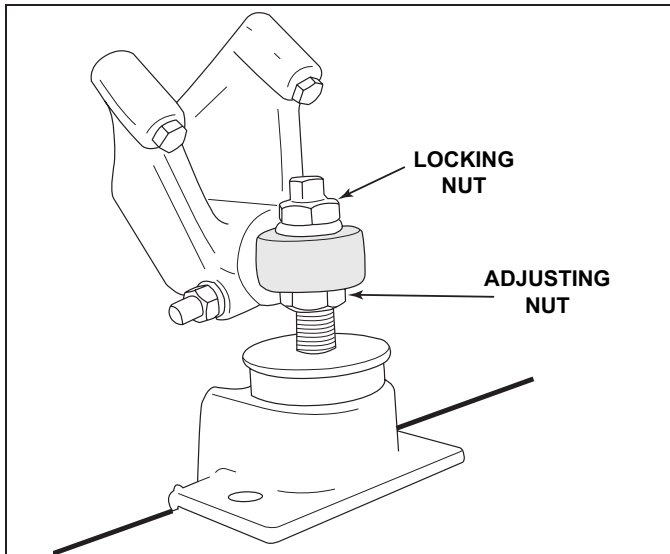

**Figure 11-29** Angular Alignment

### OFFSET ALIGNMENT:

4. If the coupler center lines are not aligned, adjust the mounts as follows:
  - UP or DOWN OFFSET ADJUSTMENT: Loosen the locking nut. Turn the adjusting nut or the adjusting bolt in the direction required to raise or lower the engine. After the adjustment is complete, tighten the locking nut.

**IMPORTANT:** Both the front mounts (or rear mounts) must be turned equally in order to keep the engine level from side to side.



**Figure 11-30** Mount Adjustment

- LEFT or RIGHT ADJUSTMENT: Loosen the trunnion clamping bolt and the nut on all four mounting brackets. Move the engine to the left or right, as necessary, to obtain the proper alignment. After adjustment is complete, tighten all bolts.

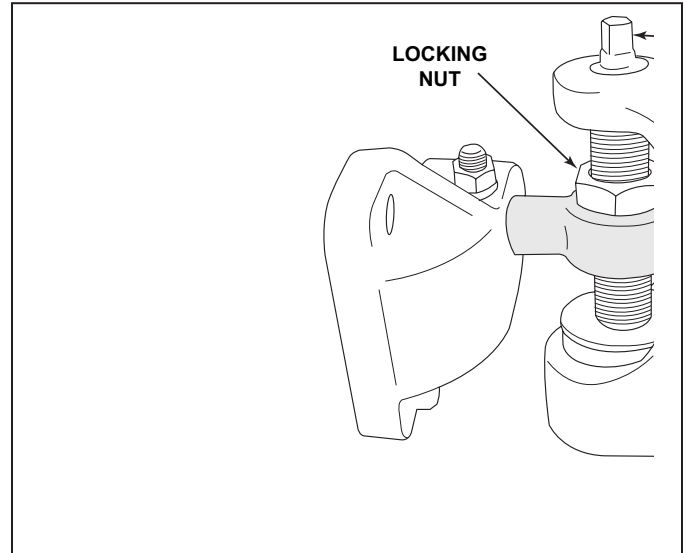

**Figure 11-31** Mount Adjustment

**IMPORTANT:** The large diameter of the mount trunnion MUST NOT extend over 1.0 in. (25.4 mm) from the mounting brackets on any of the mounts.

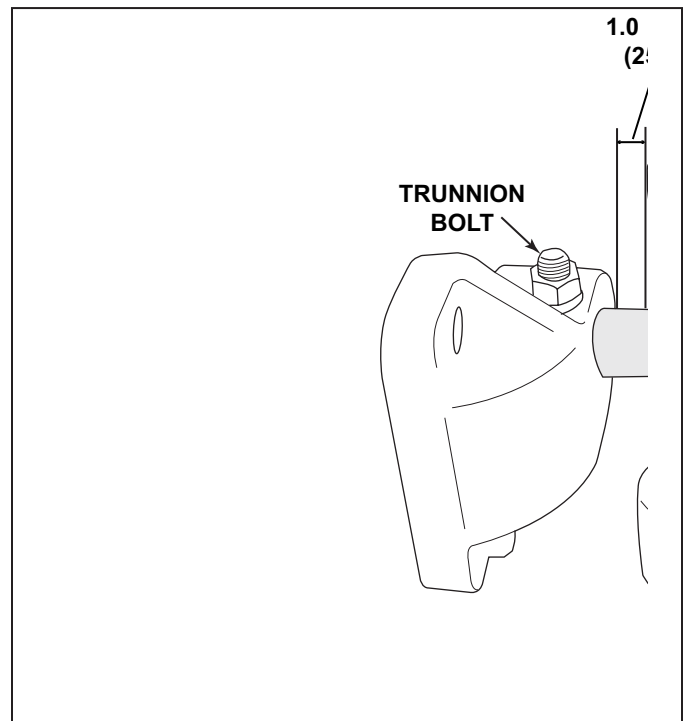

**Figure 11-32** Engine Extension

# ENGINE MAINTENANCE - 11

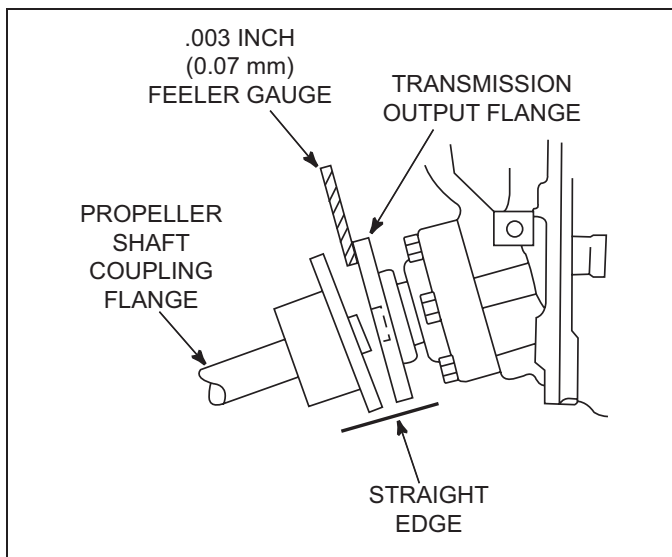

**Figure 11-33** Angular Alignment

5. Check for any angular misalignment. Hold coupling faces tightly together by hand and check for a gap between the coupling faces, with a 0.003 in. (0.07 mm) feeler gauge, at 90-degree intervals. (Figure 11-34).

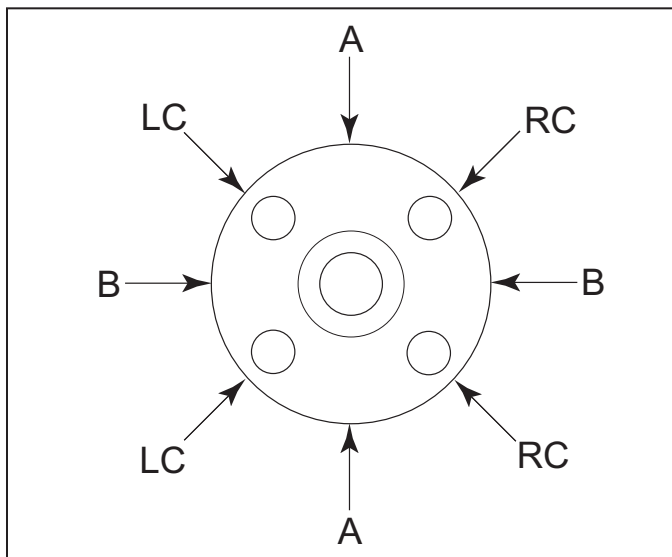

**Figure 11-34** Angular Alignment Check

**IMPORTANT:** Angular misalignment conditions may require adjustment of one front mount, both front mounts, the trunnions, or any combination. Figure 11-34 (Angular Alignment Check) and the following table are to assist in the alignment process.

Angular Misalignment	Front Mount Adjusted
A	Both
B	Trunnion
LC	R
RC	L

- To adjust a corner of the engine up or down, loosen the locking nut. Turn the adjusting nut or the adjusting bolt in the direction required to raise or lower the engine. After the adjustment is complete, tighten the locking nut.

**IMPORTANT:** If a “pinch” occurs in the “A” quadrant (Figure 11-34), correcting the condition will require an equal adjustment on the front mounts. If a “pinch” occurs in the “C” quadrant, an adjustment will be made on the opposing front mount. If a “pinch” occurs in the “B” quadrant, a trunnion adjustment is required.

- To move the engine left or right, loosen the trunnion clamping bolt and the nut on all four mounting brackets. Move the engine to the left or right, as necessary, to obtain the proper alignment. After adjustment is complete, tighten all bolts.

6. After the engine has been properly aligned, secure the engine mounts.

7. Connect the propeller shaft coupling to the transmission coupling. Tighten the coupling attaching bolts and nuts to the correct specifications.

## FASTENER TORQUE SPECIFICATIONS

Location	Lb-Ft (N·m)
Engine Mount to Stringer	Securely
Propeller	50 (68)
Trunnion Bolts	45 (61)



# ENGINE MAINTENANCE - 11

## MAINTENANCE SCHEDULE

Location and Service	Check Daily	After 1st 25 Hrs of Operation	Every 50 Hours of Operation	Every 100 Hours of Operation	Once Each Year
Check coolant level - Fresh-water cooled models only	X				
Check oil level - Engine crankcase	X				
Check oil level - Transmission	X				
Engine Assembly (complete - Check for obvious leaks (water, oil, fuel and exhaust)	X				
Remote Control and Steering System - Check for proper operation	X				
Sea Strainer - Check (if equipped)	X				
Cooling System - Check condition and tightness of all hose clamps		X		X <sup>1</sup>	X
Cooling System - Replace raw water pump impeller			X		X
Drive Belt - Inspect condition and check tension		X		X	X
Exhaust System - Check condition and tightness of all hose clamps		X		X <sup>1</sup>	X
Exhaust System - Check for water leaks at the manifold, riser and elbow gaskets	X				
Ignition System and Spark Plugs - Clean and inspect condition		O		O	O
Engine Assembly (complete) - Check for loose, missing or damaged parts (especially engine mounts, starter and alternator mounting fasteners)		X		X	X
Change engine oil and filter		X	X		X
Engine Alignment - Check and adjust if necessary		O			O
Ignition Timing - Not Adjustable					
Battery - Check electrolyte level and specific gravity. Inspect case for damage. Check cables and connections.		X	X		X
Electrical System (complete) - Check for loose or dirty connections and damaged wiring			X <sup>2</sup>		X
Flame Arrestor and Crankcase Ventilation System - Clean and inspect				X	X

# ENGINE MAINTENANCE - 11

## MAINTENANCE SCHEDULE (cont'd)

Location and Service	Check Daily	After 1st 25 Hrs of Operation	Every 50 Hours of Operation	Every 100 Hours of Operation	Once Each Year
Hoses (all) - Inspect for cracks, swelling, weather checking or other signs of deterioration				X	X
Shift and Throttle Cable Linkage - Inspect and lubricate (A)				X <sup>1</sup>	X
Fuel Filters - Service or replace		O		O	O
Transmission and "V" Drive - Change fluid (B,C) and clean strainer, if equipped		O			O

## MAINTENANCE SCHEDULE (cont'd)

Fresh-water cooled models - Clean sea-water section	As required <sup>3</sup> (X)
Fresh-water cooled models - Check coolant for alkalinity	At least once each year (X)
Fresh-water cooled models - Change coolant	Every five years
Zinc Anodes - Heat exchanger and cooler - check condition	Every 30 days <sup>3</sup> (X)
Engine Assembly Exterior Surfaces - spray with rust-preventative oil (D)	Fresh water areas - Every 60 days (X) Salt water areas - Every 30 days (X)
Cooling System (SALT WATER AREAS ONLY) - Flush sea-water section	After use each day (X)

### Notes:

(X) Denotes service to be performed by the owner/operator

(O) Denotes service to be performed by an authorized PCM Engines dealer

(A) Use SAE 30 engine oil

(B) All Velvet Drive and Hurth transmissions - Use Dexron III automatic transmission fluid

(C) All Velvet "V" Drive transmissions - Use Dexron III automatic transmission fluid

All Walters "V" Drive transmissions - Use Exxon Spartan EP-68 or SAE 30 engine oil

(D) Use WD-40 penetration oil or equivalent

<sup>1</sup> In fresh-water areas, every 100 hours of operation or 120 days (whichever occurs first). In salt-water areas, every 50 hours of operation or 60 days (whichever occurs first).

<sup>2</sup> In fresh-water areas, every 50 hours of operation or 60 days (whichever occurs first). In salt-water areas, every 25 hours of operation or 30 days (whichever occurs first).

<sup>3</sup> Requires more frequent inspection if used in extremely salty, polluted or mineral-laden waters.

<sup>4</sup> See COOLANT SPECIFICATIONS.



# ENGINE MAINTENANCE - 11

## VISUAL INSPECTION

It is important for the owner/operator to visually inspect the complete engine assembly at regular intervals. Most often, costly repairs can be avoided if potential problems are corrected before there is a failure.

Inspect the complete engine assembly for obvious fuel, oil, water or exhaust leaks. Check for loose, damaged or missing parts. Check all hose clamps for adequate tightness. Check the electrical system for loose or dirty connections or damaged wiring.

Touch up scratches, nicks and corrosion damage to the exterior finish of the engine. Spray paint may be obtained from your local PCM Engines dealer.

Protect engine finish from corrosion by periodically spraying the engine exterior finish with a rust preventative oil (such as WD-40).

## ENGINE FLUID CAPACITIES

Model	MP 5.0L / 5.7L	MP 6.0L	MP 8.1L
Crankcase Oil Capacity W / New Filter	4 Quarts (3.8 L) <sup>1</sup>	5 Quarts (4.75 L) <sup>1</sup>	7 Quarts (6.65 L) <sup>1</sup>
Fresh Water Cooling System Capacity	18 Quarts (17.03 L)	18 Quarts (17.01 L)	33 Quarts (31.35 L)

## TRANSMISSION FLUID CAPACITIES

Model	All Models	Type
PCM, 1:1 Ratio <sup>1,2</sup>	2.0 Quarts (1.9 L)	DEXRON III
PCM, 1.23:1 Ratio <sup>1,2</sup>	2.0 Quarts (1.9 L)	DEXRON III
Hurth (Exc. V-Drive), All Ratios <sup>1,2</sup>	4.0 Quarts (3.79 L)	DEXRON III
Hurth V-Drive, All Ratios <sup>1,2</sup>	4.5 - 5.0 Quarts (4.26 - 4.73 L)	DEXRON III
Walters RV-36D V-Drive	1.5 Quarts (1.42 L)	SAE 30

1 - Capacities are dependent on installation angle. Oil capacities are approximate, and may not include capacity needed for transmission cooler and oil lines. Always use the dipstick to determine the exact quantity of oil required.

2 - Check the transmission fluid level at operating temperature and immediately after shutdown of the engine.



## FILTER REQUIREMENTS

Description	Part No.
Oil Filter (remote-mounted)	R077001
Fuel Control Cell (FCC) Fuel Filter Element	RP080026

# ENGINE SPECIFICATIONS - 12

## PCM MASTER ENGINE SPECIFICATIONS

MODEL (Horsepower)	MP 5.0L (275 HP)	MP 5.7L (330 HP)	MP 8.1L (STD) (385 HP)	MP 8.1L (HO) (425 HP)	MP 6.0L (375 HP)
Displacement	5.0L (305 CID)	5.7L (350 CID)	8.1L (496 CID)	8.1L (496 CID)	6.0L (364 CID)
Bore	3.75 in. (95.0 mm)	4.0 in. (101.6 mm)	4.25 in. (107.95 mm)	4.25 in. (107.95 mm)	4.0007 in. (101.618 mm)
Stroke	3.48 in. (88.3 mm)	3.48 in. (88.3 mm)	4.370 in. (111.0 mm)	4.370 in. (111.0 mm)	3.622 in. (92.0 mm)
Compression Ratio	9.4:1	9.4:1	9.1:1	9.1:1	9.4:1
Compression Pressure	130 - 215 psi	130 - 215 psi	130 - 175 psi	130 - 175 psi	130 - 215 psi
WOT Operating RPM Preferred WOT RPM	4600-5000 4800	4800 - 5200 5000	4400 - 4800 4600	4800 - 5200 5000	4800 - 5300 5200
Cruising RPM (Max)	3800	4000	3800	4000	4000
Idle RPM (In Gear)	650 (Not Adjustable)	650 (Not Adjustable)	650 (Not Adjustable)	650 (Not Adjustable)	650 (Not Adjustable)
Oil Pressure @ 2000 RPM	25 - 60 psi (172 - 414 kPa)	25 - 60 psi (172 - 414 kPa)	25 - 60 psi (172 - 414 kPa)	25 - 60 psi (172 - 414 kPa)	25 - 80 psi (172 - 552 kPa)
Minimum Oil Pressure	10 psi (69 kPa) at Idle	10 psi (69 kPa) at Idle	10 psi (69 kPa) at Idle	10 psi (69 kPa) at Idle	10 psi (69 kPa) at Idle
Spark Plug P/N Spark Plug Gap	R030010 0.060 in.	R030010 0.060 in.	R030009 0.060 in.	R030009 0.060 in.	R030011 0.060 in.
Firing Order	1-8-4-3-6-5-7-2 (LH) 1-2-7-5-6-3-4-8 (RH)	1-8-4-3-6-5-7-2 (LH) 1-2-7-5-6-3-4-8 (RH)	1-8-7-2-6-5-4-3 (LH) NA	1-8-7-2-6-5-4-3 (LH) NA	1-8-7-2-6-5-4-3 (LH) NA
Thermostat	RWC 160°F (61.7°C) FWC 170°F (76.7°C)	RWC 160°F (61.7°C) FWC 170°F (76.7°C)	RWC 160°F (61.7°C) FWC 170°F (76.7°C)	RWC 160°F (61.7°C) FWC 170°F (76.7°C)	NA FWC 160°F (61.7°C)
Over- Temperature	193° F (89.8° C)	193° F (89.8° C)	220° F (104.8° C)	208° F (98° C)	220° F (104.8° C)
Electrical System	12 Volt Negative (-) Ground	12 Volt Negative (-) Ground	12 Volt Negative (-) Ground	12 Volt Negative (-) Ground	12 Volt Negative (-) Ground
Alternator Rating	70 Amps	70 / 100 Amps	70 / 100 Amps	70 / 100 Amps	70 Amps
Ignition Timing	Not Adjustable	Not Adjustable	Not Adjustable	Not Adjustable	Not Adjustable
CAM Retard	43-47 degrees	43-47 degrees	Not Adjustable	Not Adjustable	Not Adjustable
Battery Rating	650 CCA (Minimum) 120 Ah	650 CCA (Minimum) 120 Ah	650 CCA (Minimum) 120 Ah	650 CCA (Minimum) 120 Ah	650 CCA (Minimum) 120 Ah



PCM MASTER FUEL PRESSURE SPECIFICATIONS

MODEL (Horsepower)	MP 5.0L (275 HP)	MP 5.7L (330 HP)	MP 8.1L (STD) (385 HP)	MP 8.1L (HO) (425 HP)	MP 6.0L (375 HP)
Fuel Pressure STD. FCC	57-62 psi @ WOT	57-62 psi @ WOT	44-48 psi @ WOT	44-48 psi @ WOT	<u>MY '03 Only</u> 57-60 psi @ WOT
Fuel Pressure - FCC Returnless to Rail					<u>MY '04</u> 59-61 psi (WOT)
Fuel Pressure - LPFP ALL ENGINES	4 - 7 psi (WOT)	4 - 7 psi (WOT)	4 - 7 psi (WOT)	4 - 7 psi (WOT)	4 - 7 psi (WOT)

**IMPORTANT: FUEL PRESSURE MEASUREMENT MUST BE MADE WITH THE ENGINE UNDER LOAD.**



# ENGINE SPECIFICATIONS - 12

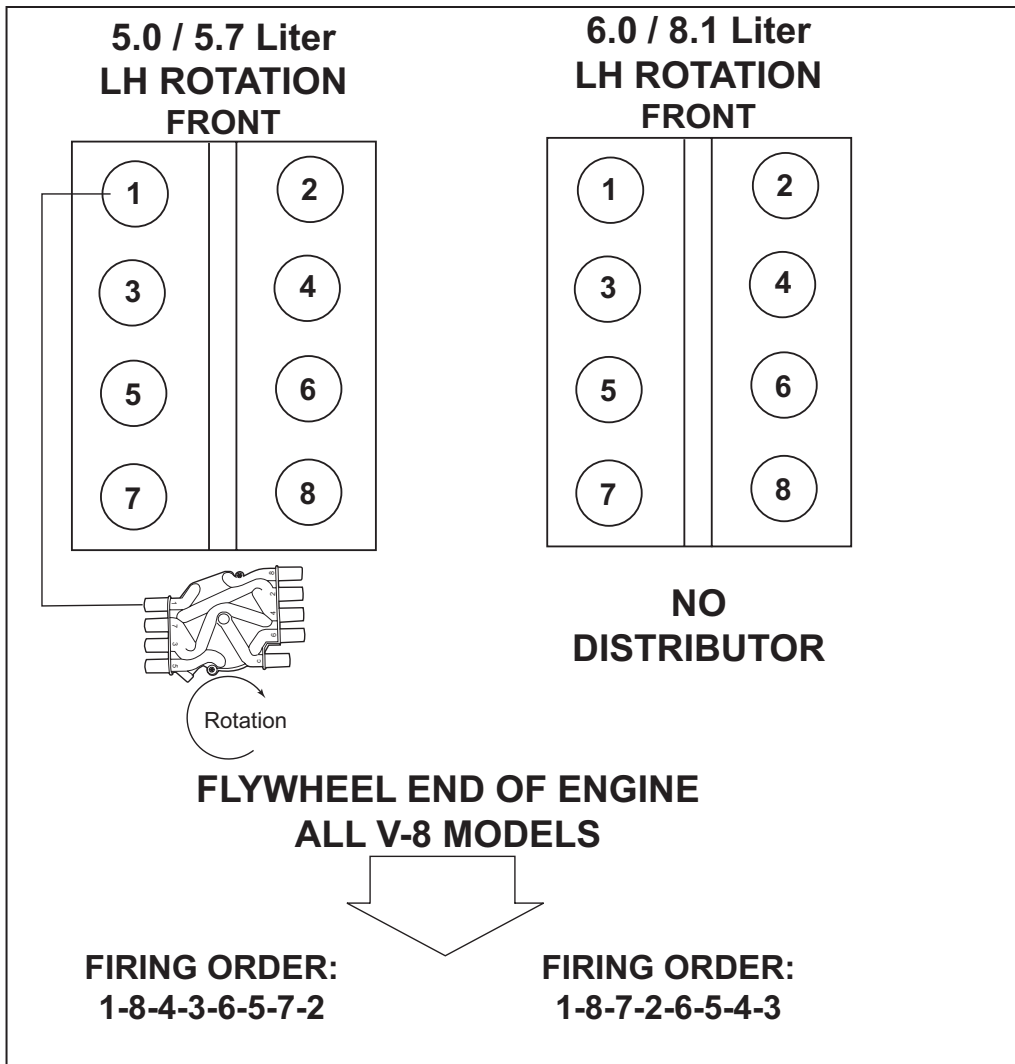

Figure 12-1 V-8 Firing Orders

## TUNE-UP SPECIFICATIONS

Model	MP 5.0L (275 HP) MP 5.7L (330 HP)	MP 6.0L (375 HP)	MP 8.1L(STD) (385 HP) MP 8.1L (HO) (425 HP)
Spark Plug Type	R030010	R030011	R030009
Spark Plug Gap	0.060 in. (1.52 mm)	0.060 in. (1.52 mm)	0.060 in. (1.52 mm)
Ignition Timing	Fixed, Not Adjustable	Fixed, Not Adjustable	Fixed, Not Adjustable
Firing Order	1-8-4-3-6-5-7-2 (LH Rotation)	1-8-7-2-6-5-4-3 (LH Rotation)	1-8-7-2-6-5-4-3 (LH Rotation)
CAM Retard	43-47 degrees	Not Adjustable	Not Adjustable

## ENGINE STORAGE

**IMPORTANT:** *These services should be performed by an Authorized PCM Dealer.*



### CAUTION

Refer to **FLUSHING COOLING SYSTEM** before proceeding.

1. Fill the fuel tanks with gasoline (that does not contain alcohol) and add a sufficient amount of gasoline stabilizer, such as STA-BIL™ fuel stabilizer, to prevent the formation of fuel gum and varnish. Follow the instructions on the container.

**IMPORTANT:** If the boat is to be placed into storage with fuel containing alcohol in the fuel tanks, the engine fuel system must be run dry at idle RPM. Fuel tanks should be drained completely and fuel conditioner, such as STA-BIL™, added to any fuel remaining in the tanks.



### WARNING

Operate the bilge blower and be sure no fuel vapors are present when treating the engine. Be sure the engine compartment is well-ventilated to prevent a potential fire hazard.

2. Run the engine and allow it to reach normal operating temperature. Shut down the engine and change the oil and oil filter (See ENGINE MAINTENANCE).
3. Flush the cooling system if operating in salt water or brackish water areas. (See ENGINE MAINTENANCE).



### WARNING

Operate the bilge blower and be sure no fuel vapors are present when treating the engine. Be sure the engine compartment is well-ventilated to prevent a potential fire hazard.

4. Restart the engine and allow it to idle for 5 minutes.

5. Turn off the ignition and remove the spark plugs. Use an aerosol-type fogging solution and spray a sufficient amount into each cylinder. (Spray 5 seconds per cylinder, minimum.) Turn the crankshaft several revolutions by hand to spread the oil evenly throughout the cylinders.

**NOTE:** If you are using a bulk type preservative oil, pour approximately one (1) teaspoon full of oil into each cylinder, through the spark plug hole, then turn the crankshaft several revolutions by hand to spread the oil evenly throughout the cylinders.

6. Install the spark plugs and connect the spark plug wires.

**NOTE:** It will be necessary to remove the spark plugs and spin the engine to eliminate excess oil prior to restarting after the storage period.

7. Remove and clean the flame arrestor and the vent hoses, and reinstall on the engine. Cover the throttle body assembly, to prevent the possibility of the water entering the engine through the throttle body assembly, during storage.

8. Close the fuel shut-off valve (if equipped).



### WARNING

**On fuel injected engines, you MUST bleed off fuel pressure before proceeding. Failure to do so may cause personal injury.**

9. Remove, empty and clean the fuel filter shell. Reinstall with a new fuel filter and gasket. Refer to Engine Maintenance for filter replacement procedures.

**NOTE:** DO NOT re-use old fuel filter components. Always replace with new fuel filter and gasket.

# OUT-OF-SEASON STORAGE - 13

## DRAINING INSTRUCTIONS



### CAUTION

If the boat is to remain in the water during or after draining, close the seacock to prevent a siphoning action that may occur, allowing sea water to flow from drain holes or removed hoses.

**IMPORTANT:** When removing the drain plugs, insert a wire into the hole to remove any obstruction which would prevent water from draining completely.

## RAW-WATER COOLED MODELS

1. Remove all the drain plugs from the following locations:
  - Cylinder Block - one on each side (5.0/5.7L engines, remove the knock sensor on the port side). When installing the knock sensor, torque to 20 N·m (15 lb ft).
  - Exhaust Manifolds - remove hoses and/or drain plugs, one on each side.
  - Transmission and Engine Cooler - one drain plug.
2. Remove the hose from the inlet side of the sea-water pump.
3. Remove the large hose from the engine circulating pump, or drain plug (if equipped).

**NOTICE:** It may be necessary to bend or lift the hoses to allow water to drain completely.

4. Remove the raw water pump impeller. (See ENGINE MAINTENANCE) If inspection proves the impeller to be in good condition, store it in an accessible spot for re-installation at the end of the storage period. A damaged or badly worn impeller should be discarded and a new one installed at the end of the storage period.

**NOTE:** Removal of the impeller during storage will prevent the impeller vanes from drying and taking a permanent "set".

5. After the water has completely drained, coat the threads of the drain plugs with PerfectSeal (or equivalent), and reinstall in the proper locations. Reinstall all the hoses and tighten the clamps securely.

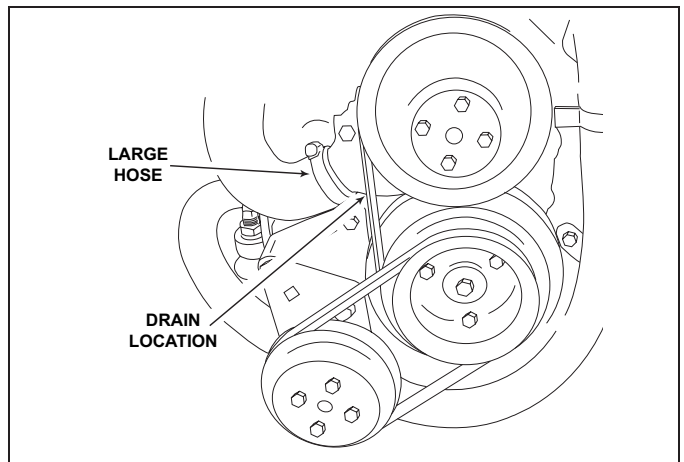

**Figure 13-1** Draining Engine Circulating Pump (5.0/5.7L)

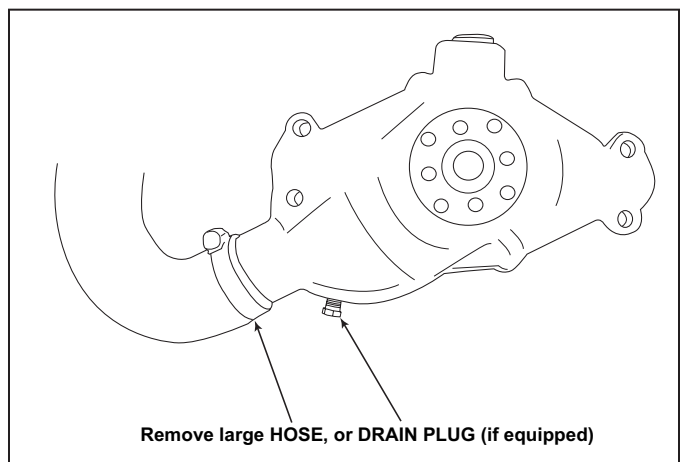

**Figure 13-2** Draining Engine Circulating Pump (5.0/5.7L)

6. Loosen the engine alternator and raw water pump drive belt(s).

**NOTICE:** For additional protection against freezing and corrosion, you may wish to fill the engine with antifreeze. If ethylene glycol based antifreeze is used, check with local environmental agencies about the proper disposal of antifreeze. It may be necessary to drain the system prior to re-commissioning the boat.

7. Remove the hoses which connect to the exhaust manifolds from the thermostat housing.
8. Remove the large circulating pump hose from the thermostat housing. Pour the mixture of antifreeze and water, properly mixed to protect the engine to the lowest temperatures that it will be exposed to, into the circulating pump hose and fill the engine block. Pour additional antifreeze solution into the hoses connected to the exhaust manifolds.

9. Reinstall the hoses into the thermostat housing and tighten the hose clamps securely.

After draining is completed, perform the additional required maintenance as outlined in the MAINTENANCE SCHEDULE under ONCE EACH YEAR.

## DRAINING INSTRUCTIONS



### CAUTION

If the boat is to remain in the water during or after draining, close the seacock to prevent a siphoning action that may occur, allowing sea water to flow from drain holes or removed hoses.

**IMPORTANT:** When removing the drain plugs, insert a wire into the hole to remove any obstruction which would prevent water from draining completely.

## FRESH-WATER COOLED MODELS

**IMPORTANT:** The fresh-water section of the cooling system must be kept filled year around with recommended coolant. Make certain that the cooling system is protected with an ethylene glycol antifreeze mixture properly mixed to protect the engine to the lowest temperature that it will be exposed to.

See the ENGINE MAINTENANCE section for testing alkalinity, draining and refilling procedures of the Fresh Water Cooling System, as required.

**IMPORTANT:** Drain the sea-water section of the cooling system only.

1. Remove all the drain plugs from the following locations:
  - Heat Exchanger - one on outboard side
  - Exhaust Manifolds - remove hoses and/or drain plugs, one on each side
  - Transmission Cooler - one drain plug
2. Remove the hose from the inlet side of the sea-water pump.
3. Remove the hose from the outlet side of the sea-water pump.

**NOTICE:** It may be necessary to bend or lift the hoses to allow water to drain completely.

4. Remove the raw water pump impeller. (See ENGINE MAINTENANCE) If inspection proves the impeller to be in good condition, store it in an accessible spot for re-installation at the end of the storage period. A damaged or badly worn impeller should be discarded and a new one installed at the end of the storage period.

**NOTE:** Removal of the impeller during storage will prevent the impeller vanes from drying and taking a permanent "set".

5. After the water has completely drained, coat the threads of drain plugs with PerfectSeal (or equivalent), and reinstall in the proper locations. Reinstall the hoses and tighten all the clamps securely.
6. Loosen the engine alternator and raw water pump drive belt(s).

After draining is completed, perform the additional required maintenance as outlined in the MAINTENANCE SCHEDULE under ONCE EACH YEAR.

## BATTERY STORAGE

Follow the battery manufacturer's instructions for storage. If not available, use the following instructions:

- Remove the battery from the boat and clean, removing dirt and grease from the top of the battery.
- Fill the battery with distilled water to the manufacturer's specifications.
- Store the battery in a cool, dry place. Do not store on a concrete surface.
- Periodically (every 30 to 45 days), check the water level and recharge the battery to the manufacturer's specifications. Do not fast charge.



### CAUTION

A discharged battery can be damaged by freezing.

# OUT-OF-SEASON STORAGE - 13

## RECOMMISSIONING AFTER STORAGE

**IMPORTANT:** *These services should be performed by an Authorized PCM Dealer.*

When recommissioning the engine after storage, the following items should be checked:

1. Assemble the raw water pump and reinstall on the engine.
2. Check all the cooling system hoses. Be sure they are properly connected and all the hose clamps are tight.



### CAUTION

When installing the battery, make certain that you connect the POSITIVE (+) BATTERY CABLE to the POSITIVE (+) BATTERY TERMINAL first, and the NEGATIVE (-) BATTERY CABLE to the NEGATIVE (-) BATTERY TERMINAL last. If the battery cables are reversed, the electrical system will be damaged.



### WARNING

Do not use jumper cables and/or a booster battery to start the engine. Do not recharge a weak battery in the boat. Remove the battery and recharge in a ventilated area away from fuel vapors, sparks or open flame.

3. Install the fully charged battery. Be sure that all the connections are clean and free from corrosion. Coat the battery terminal connections with an anti-corrosion battery terminal spray.
4. Readjust alternator and water pump drive belt tension.
5. Check engine alignment.
6. Check engine and transmission oil levels.
7. Check engine mount fasteners.



### CAUTION

Failure to remove the excess storage oil from the engine's cylinders can cause hydrostatic locking to occur, and severe damage to the engine.

8. Before starting the engine, be sure there is not an excess amount of storage oil left in the cylinders. Remove the spark plugs. Disable the fuel pumps and ignition high voltage spark by removing the MEFI System Relay. Using rags draped over the exhaust manifolds or some other suitable material or method, create a deflector or catcher for the oil that will be sprayed from the spark plug holes. Turn the ignition switch to the start position and rotate the engine three (3) or four (4) times.
9. Reinstall the MEFI System Relay.
10. Install the spark plugs and connect the spark plug wires.
11. Open the fuel shut-off valve (if equipped).
12. Refer to the OPERATING INSTRUCTIONS section and perform all the safety checks before starting the engine.
13. Refer to the Engine Maintenance section and perform the Priming the Fuel System instructions.



### CAUTION

If the engine(s) is (are) to be started prior to launching, use the procedure FLUSHING COOLING SYSTEM before proceeding to start the engine(s).

14. Open the seacock before starting the engine.
15. Start the engine and closely observe the instrument panel. Allow the engine to reach normal operating temperature. Inspect the engine carefully for fuel, exhaust, oil and water leaks.
16. Check the steering, shift and throttle controls for proper operation.



Engine performance complaints usually fall under one of the basic headings listed in the Troubleshooting Guide. When a problem cannot be easily diagnosed, consult a PCM Engines Servicing Dealer for assistance.

Malfunction	Possible Cause	Corrective Action
<p><b>Engine will not crank with the starter motor, or cranks slowly.</b></p> <p><b>NOTICE:</b> Battery voltage must be AT or ABOVE 10 volts while the engine is cranking or the engine management system will not function.</p>	<p>Problem with the engine management system.</p> <p>Battery switch turned OFF (if equipped)</p> <p>Remote control not in Neutral position.</p> <p>Blown the ignition fuse or open circuit breakers.</p> <p>Loose and/or dirty wiring connections.</p> <p>Dead Battery</p>	<p>Contact PCM Engines Dealer.</p> <p>Turn the battery switch ON.</p> <p>Position the remote control exactly in Neutral.</p> <p>Replace the fuse - reset circuit breakers.</p> <p>Check the battery cables and starter circuit wiring. Clean and tighten all connections. Repair or replace the damaged wiring.</p> <p>Recharge, test and replace as necessary.</p>
<p><b>Engine Cranks - will not start or is hard starting.</b></p> <p><b>NOTICE:</b> Battery voltage must be AT or ABOVE 10 volts while the engine is cranking or the engine management system will not function.</p>	<p>Improper starting procedure.</p> <p>No fuel - empty fuel tank</p> <p>No fuel to the throttle body (TBI) or the injectors (MPI)</p> <p>Engine flooded</p> <p>Ignition system malfunction</p> <p>Contaminated fuel</p>	<p>Refer to "STARTING ENGINE" in the OPERATING INSTRUCTIONS section.</p> <p>Check the fuel tank level - fill tank(s). Open shut-off valve(s).</p> <p>Plugged fuel filters. Plugged or kinked fuel lines or plugged fuel-tank vent. Faulty fuel pump - check electrical connections. Faulty anti-siphon valve.</p> <p>Open the throttle 100% and crank the engine. When the engine starts, immediately return the throttle to 1000 RPM.</p> <p>Contact PCM Engines Dealer.</p> <p>Check fuel for water or other contamination. If contaminated, drain and clean the fuel system.</p>



# TROUBLESHOOTING - 14

Malfunction	Possible Cause	Corrective Action
<p><b>Engine Overheats</b></p> <p><i>The following applies to engines equipped with Fresh-Water Cooling (FWC) systems.</i></p>	<p>Loose or worn drive belt(s)</p> <p>Collapsed, kinked or leaking hoses.</p> <p>Transmission/engine oil cooler plugged</p> <p>Faulty thermostat</p> <p>Sea-water intake valve partially/fully closed.</p> <p>Restricted sea-water pickup</p> <p>Faulty temperature sending unit or gauge</p> <p>Sea-water pump impeller worn or damaged</p> <p>Coolant level low in the fresh-water section of the cooling system</p> <p>Heat exchanger passages plugged with scales and debris</p> <p>Improper coolant mixture</p>	<p>Adjust or replace the belts as necessary.</p> <p>Replace the hoses.</p> <p>Remove the water hoses and flush in opposite direction of the normal flow.</p> <p>Replace the thermostat.</p> <p>Open the valve completely.</p> <p>Remove restriction.</p> <p>Test and replace as necessary.</p> <p>Replace the impeller.</p> <p>Check the cooling system for leaks. Refill the system. See Warning before removing the fill cap.</p> <p>Clean and flush the exchanger.</p> <p>Install the proper coolant mixture (50% antifreeze - 50% water).</p>
<p><b>Insufficient engine temperature</b></p>	<p>Faulty thermostat</p> <p>Faulty temperature sender</p>	<p>Replace the thermostat.</p> <p>Replace the temperature sender.</p>
<p><b>Engine oil pressure low</b></p>	<p>Faulty oil pressure sending unit or gauge</p> <p>Oil level low</p> <p>Crankcase overfilled causing oil aeration</p> <p>Diluted or improper grade/viscosity of oil</p>	<p>Test and replace as necessary.</p> <p>Add specified oil. Check the engine for leaks.</p> <p>Remove the required amount of oil. Determine the cause of overfilled condition (improper filling, etc.).</p> <p>Change the oil and filter. Determine the cause of dilution. (insufficient engine temperature, excessive idling, etc.)</p>

Malfunction	Possible Cause	Corrective Action
<b>Transmission slipping - erratic operation</b>	<p>Low oil level</p> <p>Transmission overfilled causing oil aeration</p> <p>Transmission shift lever not fully engaged</p> <p>Contaminated fluid</p>	<p>Add specified oil. Check the transmission for leaks.</p> <p>Drain required amount of oil.</p> <p>Adjust the shift linkage and remote control. Check the shift cables for freedom of movement and binding.</p> <p>Determine and correct the contamination source and change the fluid.</p>
<b>Engine misses, runs rough and/or backfires</b>	<p>Ignition system malfunction</p> <p>Plugged fuel filters</p> <p>Faulty fuel pump.</p> <p>Plugged or kinked fuel lines or fuel tank vent</p> <p>Anti-siphon valve faulty</p> <p>Flame arrestor dirty</p>	<p>Contact PCM Engines Dealer.</p> <p>Replace the fuel filters.</p> <p>Have fuel pump replaced by a PCM Engines Dealer/</p> <p>Repair or replace the fuel lines. Remove obstruction.</p> <p>Clean or replace as necessary.</p> <p>Clean the flame arrestor.</p>
<b>Poor engine or boat performance</b>	<p>Ignition malfunction</p> <p>Throttle not fully open</p> <p>Damaged or improper propeller</p> <p>Excessive water in the bilge</p> <p>Excessive growth on the boat bottom</p> <p>Boat overloaded</p> <p>Dirty flame arrestor</p> <p>Engine overheating</p>	<p>Contact PCM Engines Dealer.</p> <p>Check the remote control and throttle body linkage for freedom of movement and proper adjustment.</p> <p>Repair or replace as necessary.</p> <p>Pump the water out and investigate source of entry.</p> <p>Clean the bottom and paint with an anti-fouling paint.</p> <p>Reduce and/or redistribute the load.</p> <p>Clean the flame arrestor.</p> <p>Repair the cooling system (See "Engine Overheats").</p>

# WATER FLOW DIAGRAMS - 15

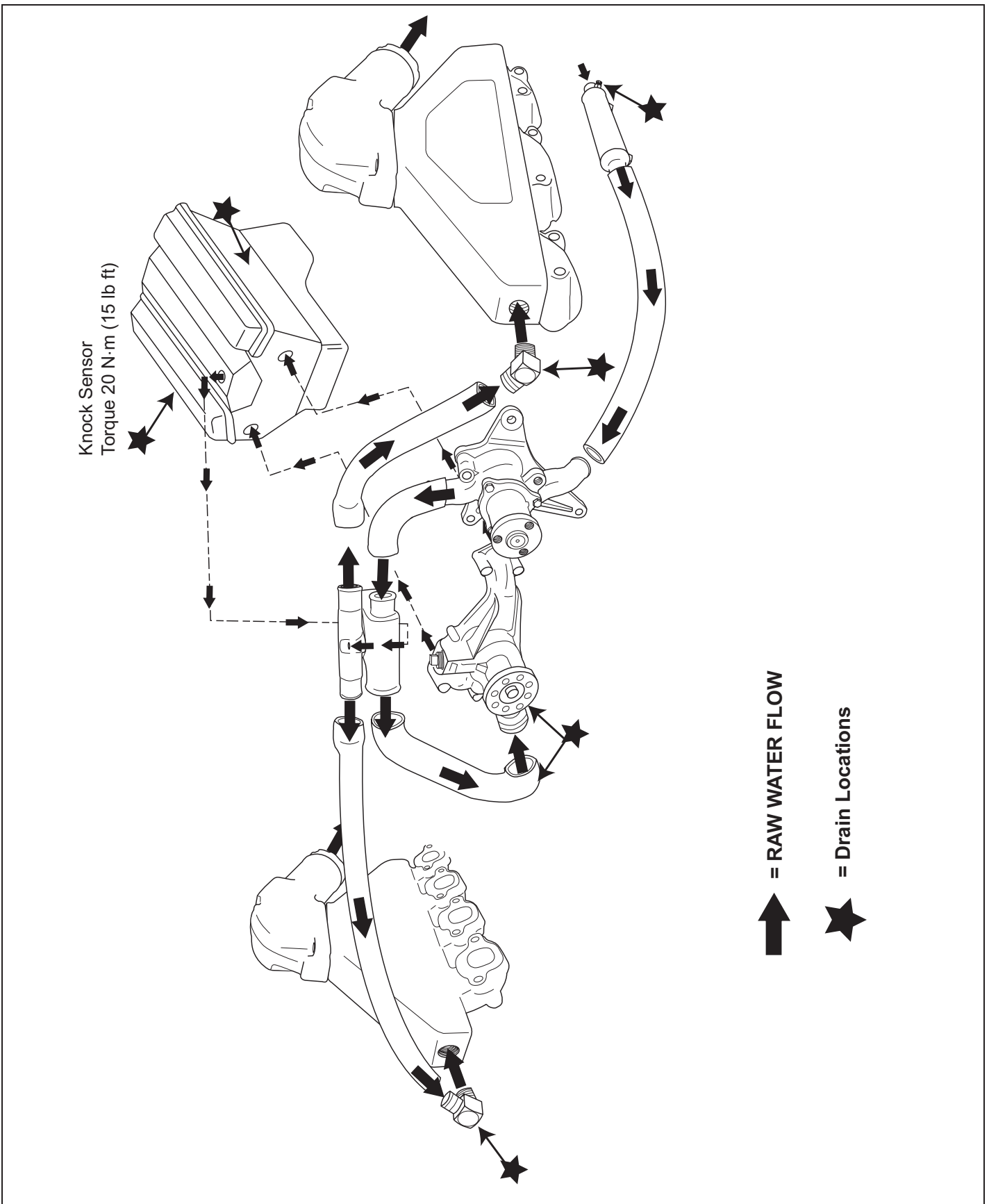

Figure 15-1 Raw-Water Cooling System (5.0/5.7L Modular Raw Water Pump)

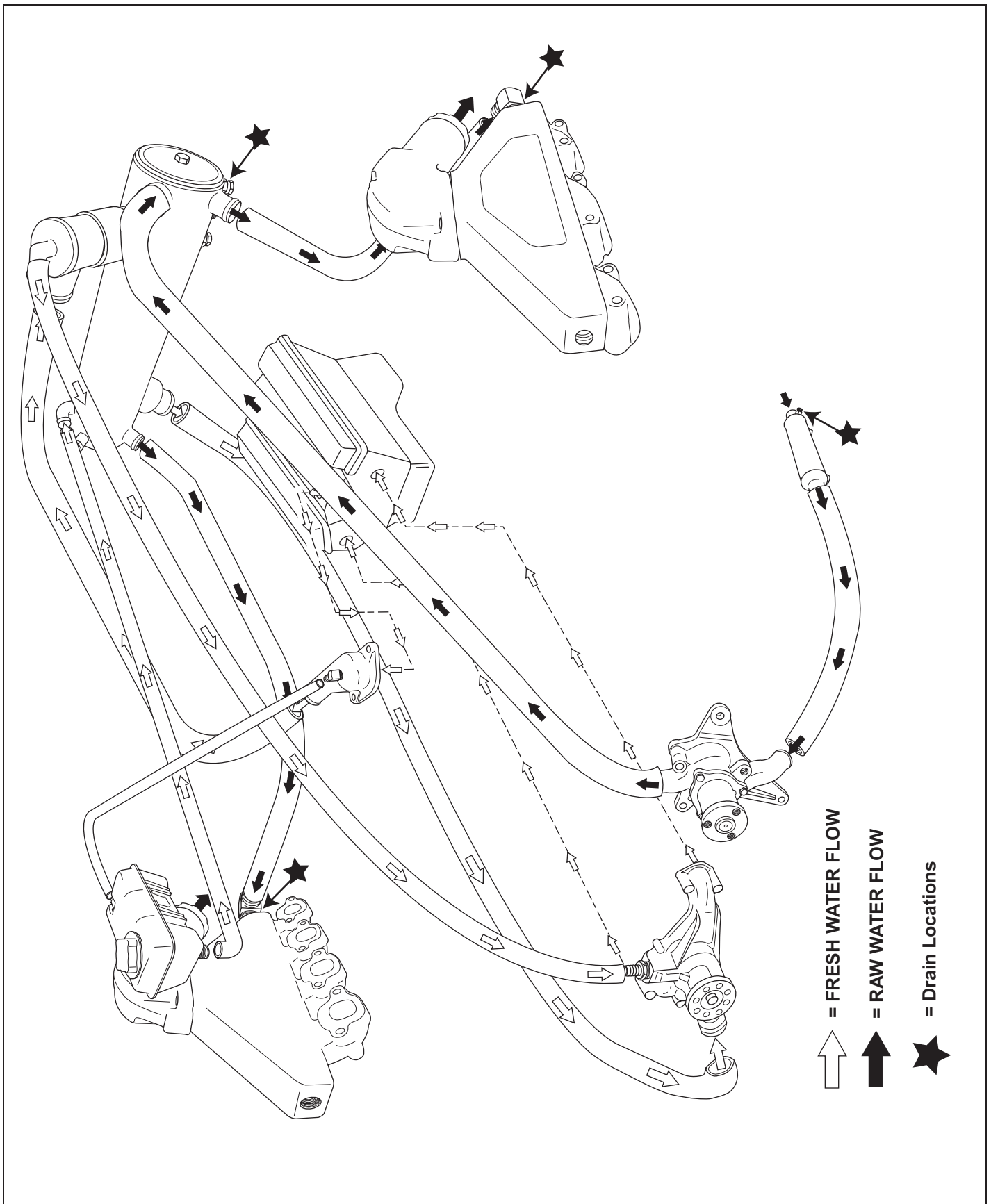
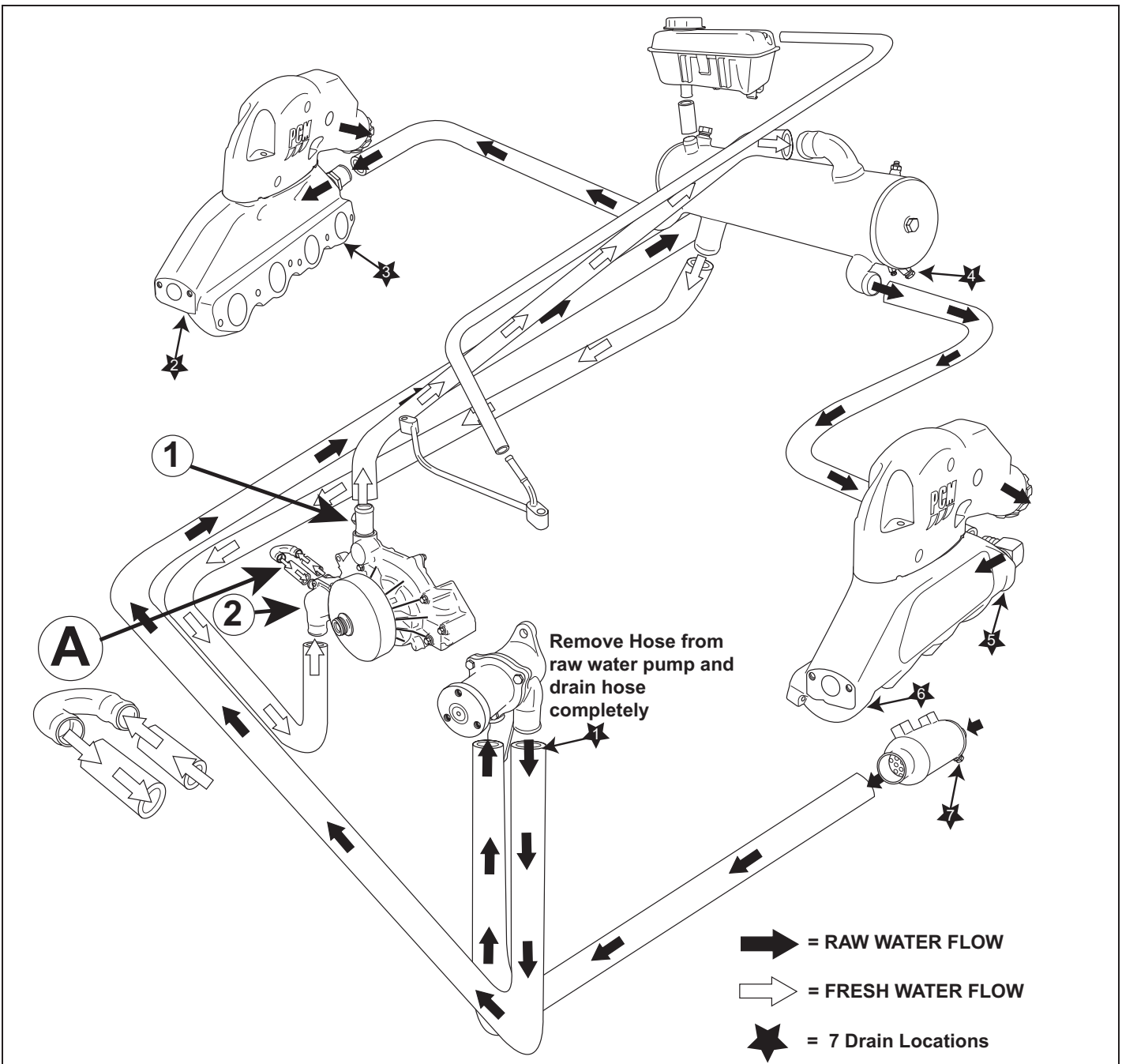

Figure 15-2 Fresh-Water Cooling System (5.0/5.7L)

# WATER FLOW DIAGRAMS - 15



**IMPORTANT: Accessory (i.e. heater, hot water tank) Hook Up**  
 A tee may be inserted anywhere in the specified hose for most appropriate routing.

Location ① - Water OUT to heater or hot water tank

Location ② - Water RETURN from heater or hot water tank

**NOTE:** Location A is the cooling system bypass. This bypass hose **MUST NOT** be tampered with. **DO NOT** hook up any external accessories (i.e. heaters, hot water tanks) at this location.

**Figure 15-3** Fresh-Water Cooling System (6.0L)

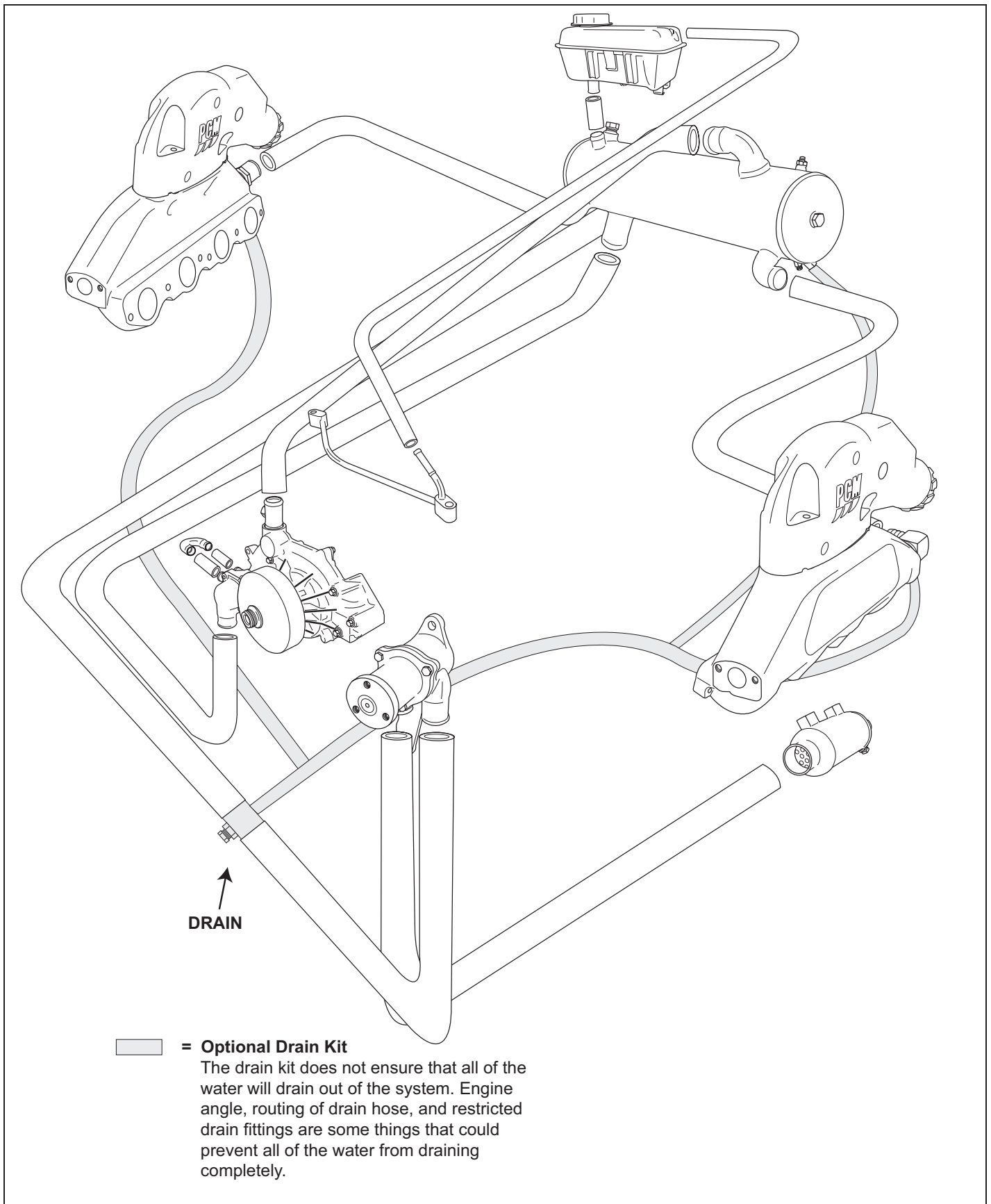

**Figure 15-4** Water Drain kit - Optional (6.0L)

# WATER FLOW DIAGRAMS - 15

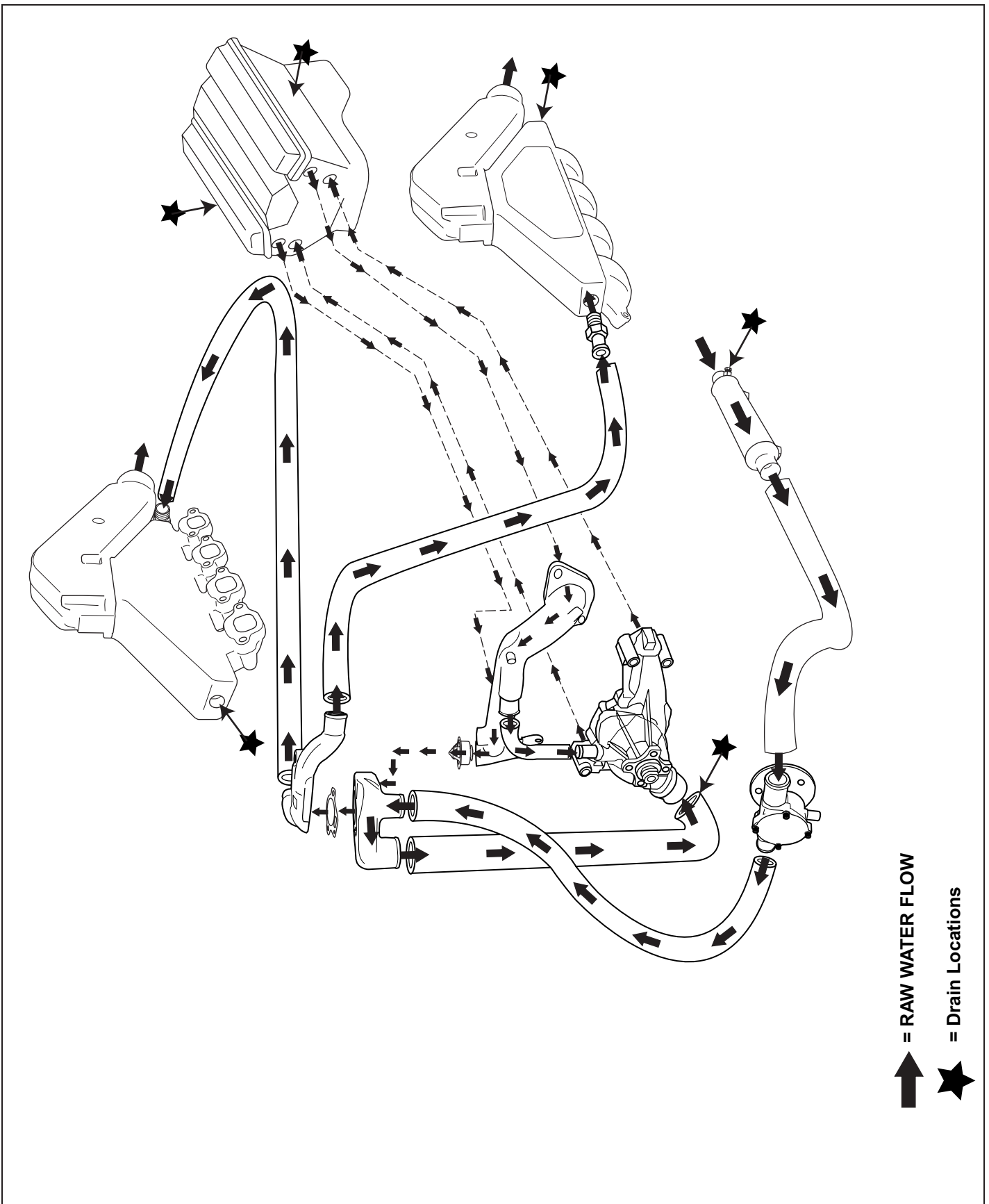

Figure 15-5 Raw-Water Cooling System (8.1L)



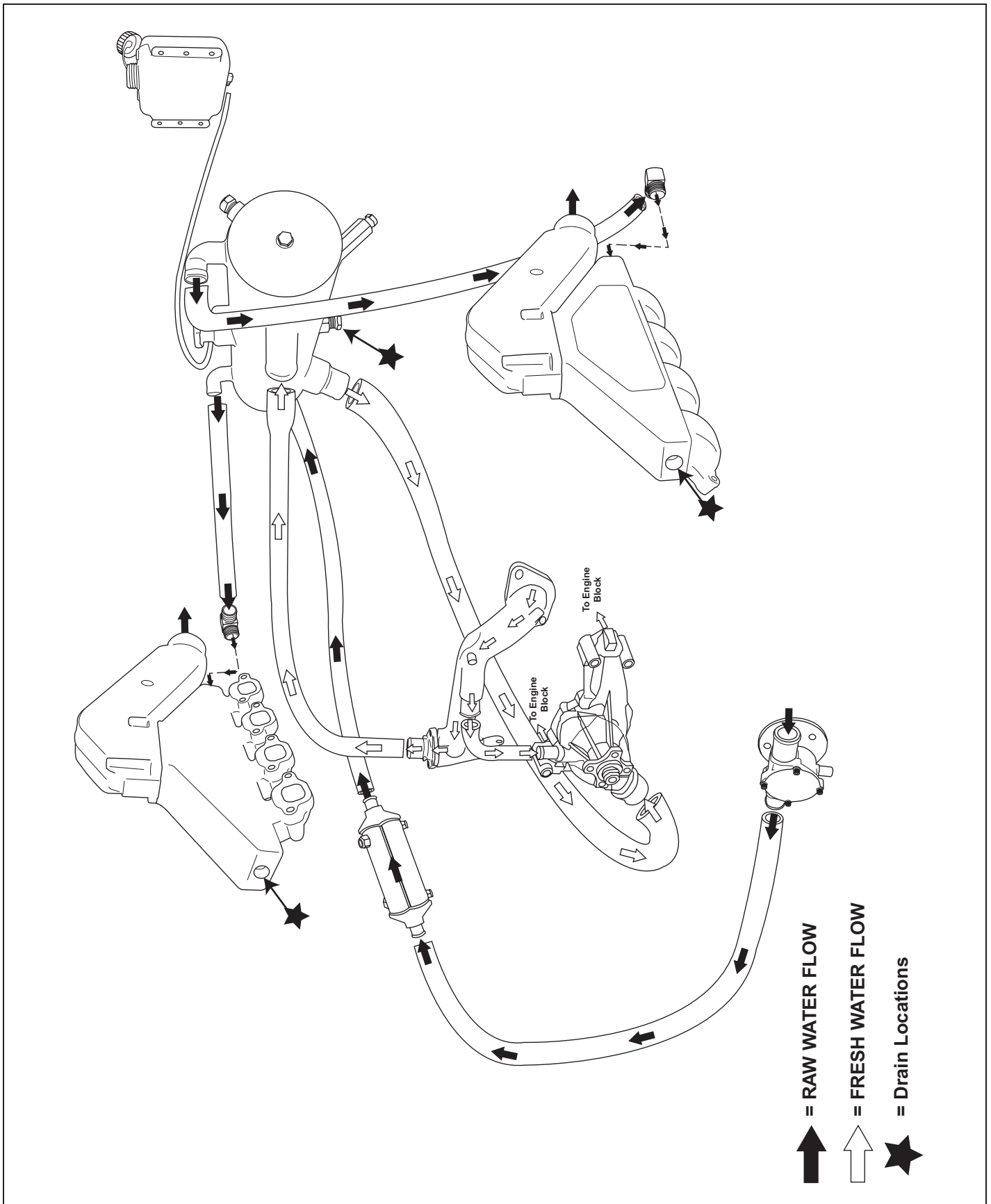
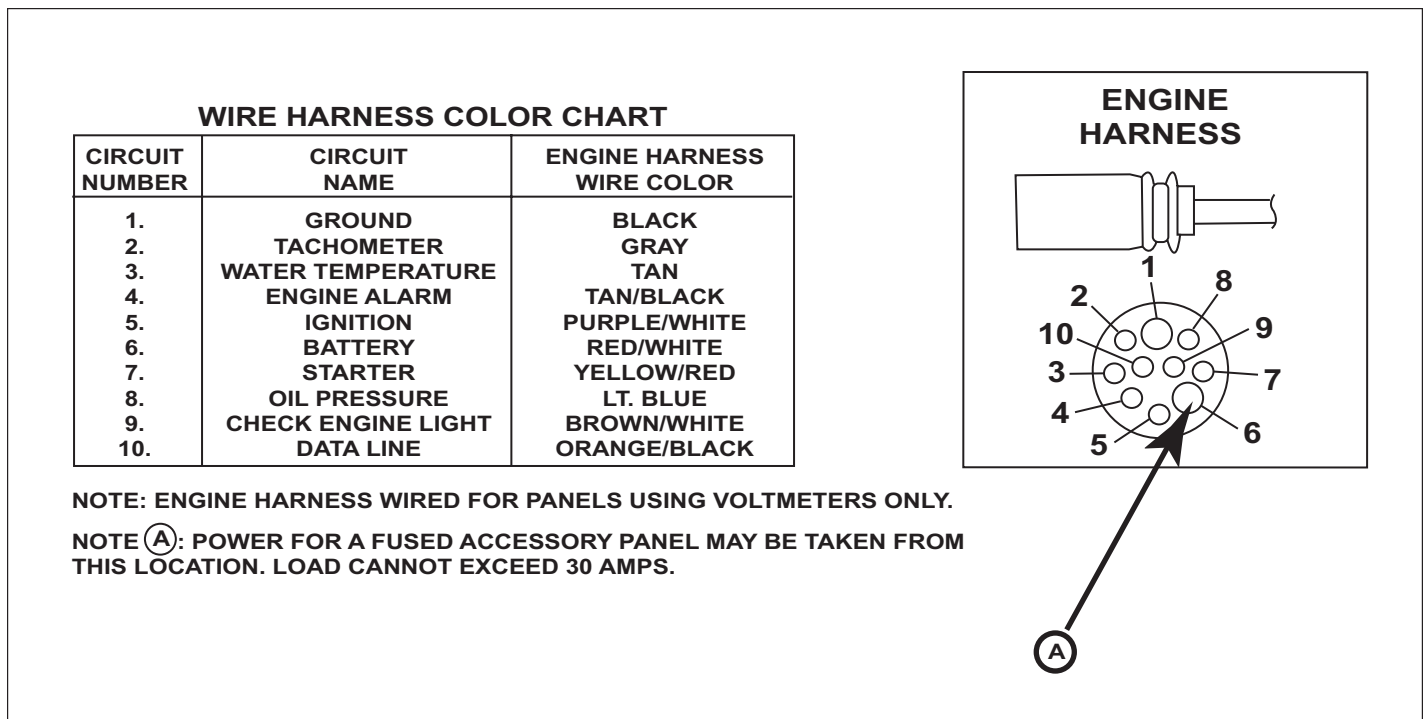

Figure 15-5 Fresh-Water Cooling System (8.1L)

# INSTRUMENTATION WIRING DIAGRAMS - 16



*Figure 16-1* Typical Instrumentation Wiring

To obtain service and/or parts literature for your PCM Marine Engine, contact the following:

PCM Engines  
Pleasurecraft Engine Group  
Publications Department  
1737 Highway 76 East  
Little Mountain, SC 29075

1. **SERVICE:** For more detailed information, PCM has a detailed service manual available. This manual contains complete engine and component disassembly and reassembly instructions. Troubleshooting and maintenance charts are also included.
2. **PARTS:** Parts manuals with exploded views for service parts are available for all current engine models.

**IMPORTANT:** When contacting the factory for service information, be sure to include your engine model and serial number to insure the service information you receive is correct.



# FORMS - 18

## PCM WARRANTY TRANSFER APPLICATION

The remainder of the original PCM limited warranty is transferable **within thirty (30) days of date of sale** by the original owner/user to a subsequent purchaser for the remainder of the unused portion of the original warranty term, **provided the engine does not have in excess of 300 hours**. The original date of sale or original in-service date (whichever comes first) begins the warranty coverage period.

### Direct Sale by Owner/Dealer Promo/Ski Show User/ or First Operator:

- The second purchaser can be registered as the owner and retain the unused portion of the warranty term by sending the following:
  - Original owner's Warranty Registration Card
  - Copy of Bill of Sale/Sales Contract/Operator Contract
  - Completed Warranty Transfer Application
  - Warranty transfer fee

### Transfer Fee:

- The fee for transfer is \$100.00.** The applicable transfer fee must be submitted via certified check **within 30 days of date of sale** along with the transfer application information to:  
Pleasurecraft Engine Group  
P.O. Drawer 369  
Little Mountain, S.C., 29075
- A Warranty Registration Card will be issued to the second owner, reflecting the change has been made in the factory computer.

**OUTSIDE THE U.S. AND CANADA, CONTACT YOUR LOCAL PLEASURECRAFT DEALER OR WARRANTY SERVICES AT (803) 345-0050 FOR MORE INFORMATION ON HOW TO APPLY TO THIS PROGRAM.**

**IMPORTANT! PURCHASER NOTICE:** The checks listed below are designed to insure safety and satisfaction. A step-by-step procedure for pre-delivery can be found in Course 1 of the PCM E-Train Program. Therefore, we require the following inspection be performed at your expense by a qualified technician prior to delivery. By signature the technician certifies that he/she has checked the installation and operation of the engine and finds it to be performing properly. All terms in the Limited Warranty located in the Engine Owners Manual still apply.

**ENGINE MODEL:** \_\_\_\_\_ **ENGINE SERIAL:** \_\_\_\_\_  
**TRANS. SERIAL:** \_\_\_\_\_ **ENGINE HOURS:** \_\_\_\_\_  
**HULL SERIAL #:** \_\_\_\_\_

### Pre-Delivery Checklist

- |   |   |
|---|---|
| <input type="checkbox"/> Check for Bulletins  | <input type="checkbox"/> Belt and Pulley: Inspect for Damage              |
| <input type="checkbox"/> Engine Oil: Check  | <input type="checkbox"/> All Drain Plugs: Confirm Proper Installation     |
| <input type="checkbox"/> Drive Lube: Check  | <input type="checkbox"/> All Fuel Lines: Confirm No Leaks                 |
| <input type="checkbox"/> Battery Rating, Charge, and Level: Check   | <input type="checkbox"/> All Oil Lines: Confirm No Leaks                  |
| <input type="checkbox"/> Control Adjustments: Confirm Proper Operation  | <input type="checkbox"/> All Water Lines: Confirm No Leaks                |
| <input type="checkbox"/> Gauges: Check for Proper Operation   | <input type="checkbox"/> Electrical Wiring: Check for Proper Installation |
| <input type="checkbox"/> Record Propeller Size, Rotation and WOT<br>WOT RPM _____ Diameter _____ Pitch _____ Rotation _____ |   |
| <input type="checkbox"/> Record Fuel Pressure, Idle _____<br>Record Fuel Pressure, WOT _____                                | <input type="checkbox"/> Trouble Codes Checked<br>Trouble Codes Cleared   |
| <input type="checkbox"/> Dealer Reviewed Warranty with Owner  |   |

DATE OF SALE (2ND Owner) \_\_\_\_/\_\_\_\_/\_\_\_\_

DATE OF SALE (1st Owner/1st Operator) \_\_\_\_/\_\_\_\_/\_\_\_\_

(New Owner)  
NAME: \_\_\_\_\_

(Previous Owner)  
NAME: \_\_\_\_\_

ADDRESS: \_\_\_\_\_

ADDRESS: \_\_\_\_\_

CITY, STATE, ZIP \_\_\_\_\_

CITY, STATE, ZIP \_\_\_\_\_

I hereby certify the pre-delivery checklist on engine # \_\_\_\_\_ and have corrected any abnormality revealed by this inspection.

\_\_\_\_\_  
(Technician Signature, Dealer & Date)

\_\_\_\_\_  
(Seller's Signature & Date)

\_\_\_\_\_  
(Purchaser's Signature & Date)



**PCM**

**SUMMARY OF WARRANTY TERM LIMITS**

This list does not, in any way, modify the official Limited Warranty Statement of PCM. This list has been compiled only as a general outline of year and hour limits imposed on different models of PCM engines. Please review the official Limited Warranty Statements on the following pages for specific terms and limitations as they apply to the particular engine / component involved.

**ENGINE MODEL YEAR:**

**WARRANTY COVERAGE TERM:**

1992 & OLDER	1 year, 200 hours. Engine and Transmission.
1993	2 years, 200 hours. Engine and Transmission
1994 - 1996	3 years, 200 hours, Ford engine. 2 years, 200 hours Transmission. 2 years, 200 hours, GM engine. 2 years, 200 hours. Transmission.
1997* - 1999	3 years, unlimited hours, Ford and GM. 2 years, unlimited hours Transmission.
2000	3 years, unlimited hours, Ford and GM. 3 years, unlimited hours Transmission.
2001**	3 years, unlimited hours, Ford and GM. 3 years, unlimited hours Transmission
2002 **	3 years, unlimited hours, Ford and GM. 3 years, unlimited hours Transmission
2003	3 years, unlimited hours, GM. 3 years, unlimited hours Transmission
2004	3 years, unlimited hours, GM. 3 years, unlimited hours Transmission
Base Engine	1 year, 200 hours with exclusions.

Note:

- \* 1997 model year engine in a Correct Craft vessel offered 3 Year Warranty on GM engines
- \* 1997 PCM and later model year engines offered transferable warranty. (Does not apply to any earlier model)
- \*\* Special 25th Anniversary Edition PCM Ford GT-40 engines have a fourth year of product protection on all internal engine components supplied by Ford Power Products.

**PCM OWNERSHIP CHANGE NOTICE**

If you are the new owner of a Pleasurecraft Marine Engine on which the warranty has expired and would like to inform Pleasurecraft of your ownership for notification purposes in case of Service Updates, Recalls, etc., complete the section below and return by mail to PCM. PO Drawer 369, Little Mountain, SC 29075.

**ENGINE MODEL:** \_\_\_\_\_

**ENGINE SERIAL NUMBER:** \_\_\_\_\_

**TRANS. MODEL:** \_\_\_\_\_

**TRANS. SERIAL NUMBER:** \_\_\_\_\_

**(New Owner) NAME:** \_\_\_\_\_

**ADDRESS:** \_\_\_\_\_

**CITY,STATE,ZIP:** \_\_\_\_\_

**DATE OF PURCHASE:** \_\_\_\_\_

**(Previous Owner)NAME:** \_\_\_\_\_

**ADDRESS:** \_\_\_\_\_

**CITY,STATE,ZIP:** \_\_\_\_\_





PROBLEM NOTIFICATION OR INFORMATION REQUEST FORM

IMPORTANT: All blanks MUST be completed to insure proper identification of your engine which is necessary to properly understand your request.

When completed, mail this form to:

Pleasurecraft Marine
PO Drawer 369
Little Mountain, SC 29075

Engine Model \_\_\_\_\_ Engine Serial Number \_\_\_\_\_ Gear Serial Number \_\_\_\_\_

Owner Information

Name \_\_\_\_\_ Telephone (\_\_\_\_) \_\_\_\_\_

Address \_\_\_\_\_

City \_\_\_\_\_ State \_\_\_\_\_ Zip \_\_\_\_\_

Selling Dealer \_\_\_\_\_

Dealers Address \_\_\_\_\_

Date of Purchase \_\_\_\_\_ Boat Make \_\_\_\_\_ Length \_\_\_\_\_ Type \_\_\_\_\_

Gentlemen, I would like to inform you of a problem I have experienced with the above engine. My problem is:

Multiple horizontal lines for writing the problem description.

My boat is located at \_\_\_\_\_

Address \_\_\_\_\_ Telephone (\_\_\_\_) \_\_\_\_\_

City \_\_\_\_\_ State \_\_\_\_\_ Zip \_\_\_\_\_

Requestors Signature \_\_\_\_\_ Date \_\_\_\_\_



